

OM SENI

MBRS2H100T3G

MBRA2H100T3G

Surface Mount Schottky Power Rectifier

SMA/SMB Power Surface Mount Package

This device employs the Schottky Barrier principle in a metal-to-silicon power rectifier. Features epitaxial construction with oxide passivation and metal overlay contact. Ideally suited for low voltage, high frequency switching power supplies; free wheeling diodes and polarity protection diodes.

Features

- Compact Package with J-Bend Leads Ideal for Automated Handling
- Highly Stable Oxide Passivated Junction
- Guard-Ring for Overvoltage Protection
- Low Forward Voltage Drop

Mechanical Characteristics

- Case: Molded Epoxy
- Weight: 70 mg (SMA), 95 mg (SMB) (Approximately)
- Cathode Polarity Band
- Lead and Mounting Surface Temperature for Soldering Purposes: 260°C Max. for 10 Seconds
- Finish: All External Surfaces Corrosion Resistant and Terminal Leads are Readily Solderable
- ESD Ratings:
 - ◆ Machine Model = C
 - ◆ Human Body Model = 3B
- These Devices are Pb-Free and are RoHS Compliant
- Device Meets MSL1 Requirements

SCHOTTKY BARRIER RECTIFIER 2.0 AMPERES, 100 VOLTS

MARKING DIAGRAMS



SMA
CASE 403D

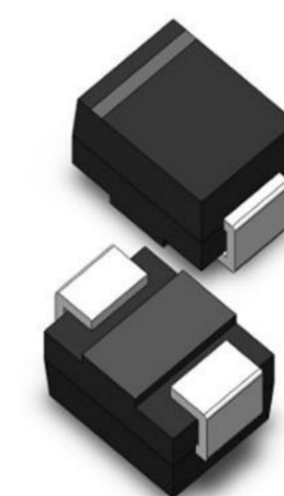
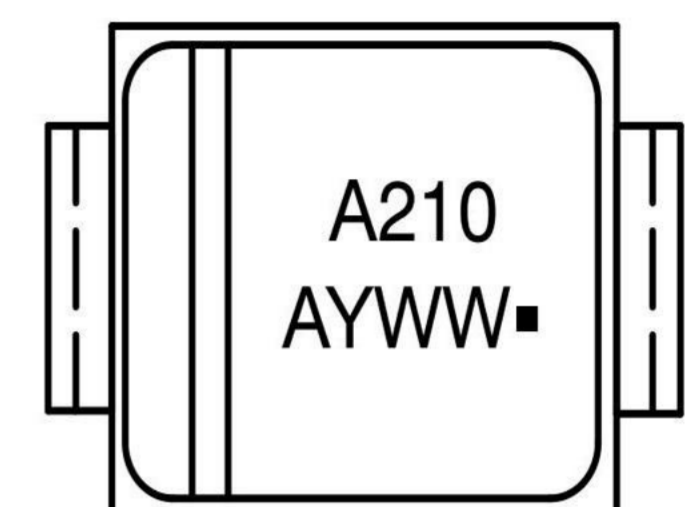

SMB
CASE 403A

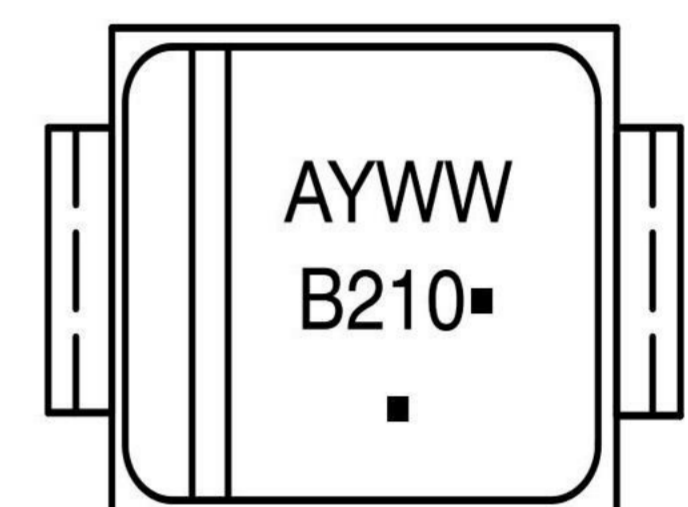

A210 = MBRA2H100T3G
NRVBA2H100T3G
B210 = MBRS2H100T3G
NBRS2H100T3G

A = Assembly Location

Y = Year

WW = Work Week

▪ = Pb-Free Package

(Note: Microdot may be in either location)

**The Assembly Location code (A) is front side optional. In cases where the Assembly Location is stamped in the package, the front side assembly code may be blank.

ORDERING INFORMATION

Device	Package	Shipping [†]
MBRA2H100T3G	SMA (Pb-Free)	5,000 / Tape & Reel
MBRS2H100T3G	SMB (Pb-Free)	2,500 / Tape & Reel

[†]For information on tape and reel specifications, including part orientation and tape sizes, please refer to our Tape and Reel Packaging Specifications Brochure, BRD8011/D.

OM SENI

MAXIMUM RATINGS

Rating	Symbol	Value	Unit
Peak Repetitive Reverse Voltage Working Peak Reverse Voltage DC Blocking Voltage	V_{RRM} V_{RWM} V_R	100	V
Average Rectified Forward Current ($T_L = 150^\circ\text{C}$)	I_O	2.0	A
Non-Repetitive Peak Surge Current (Surge Applied at Rated Load Conditions Halfwave, Single Phase, 60 Hz)	I_{FSM}	130	A
Storage Temperature Range	T_{stg}	-65 to +175	$^\circ\text{C}$
Operating Junction Temperature (Note 1)	T_J	-65 to +175	$^\circ\text{C}$

Stresses exceeding those listed in the Maximum Ratings table may damage the device. If any of these limits are exceeded, device functionality should not be assumed, damage may occur and reliability may be affected.

1. The heat generated must be less than the thermal conductivity from Junction-to-Ambient: $dP_D/dT_J < 1/R_{\theta JA}$.

THERMAL CHARACTERISTICS

Characteristic	Symbol	Value	Unit
Thermal Resistance, Junction-to-Lead (Note 2) MBRA2H100T3G MBRS2H100T3G	Ψ_{JCL}	14 12	$^\circ\text{C}/\text{W}$
Thermal Resistance, Junction-to-Ambient (Note 2) MBRA2H100T3G MBRS2H100T3G	$R_{\theta JA}$	75 71	$^\circ\text{C}/\text{W}$
Thermal Resistance, Junction-to-Ambient (Note 3) MBRA2H100T3G MBRS2H100T3G	$R_{\theta JA}$	275 230	$^\circ\text{C}/\text{W}$

2. Mounted with 700 mm square copper pad size (Approximately 1 inch square) 1 oz FR4 Board.

3. Mounted with minimum recommended pad size 1 oz FR4 Board.

ELECTRICAL CHARACTERISTICS

Characteristic	Symbol	Value		Unit
		$T_J = 25^\circ\text{C}$	$T_J = 125^\circ\text{C}$	
Maximum Instantaneous Forward Voltage (Note 4) ($i_F = 2.0 \text{ A}$)	V_F	0.79	0.65	V
Maximum Instantaneous Reverse Current (Note 4) ($V_R = 100 \text{ V}$)	I_R	0.008	1.5	mA

4. Pulse Test: Pulse Width $\leq 380 \mu\text{s}$, Duty Cycle $\leq 2.0\%$.

OM SENI

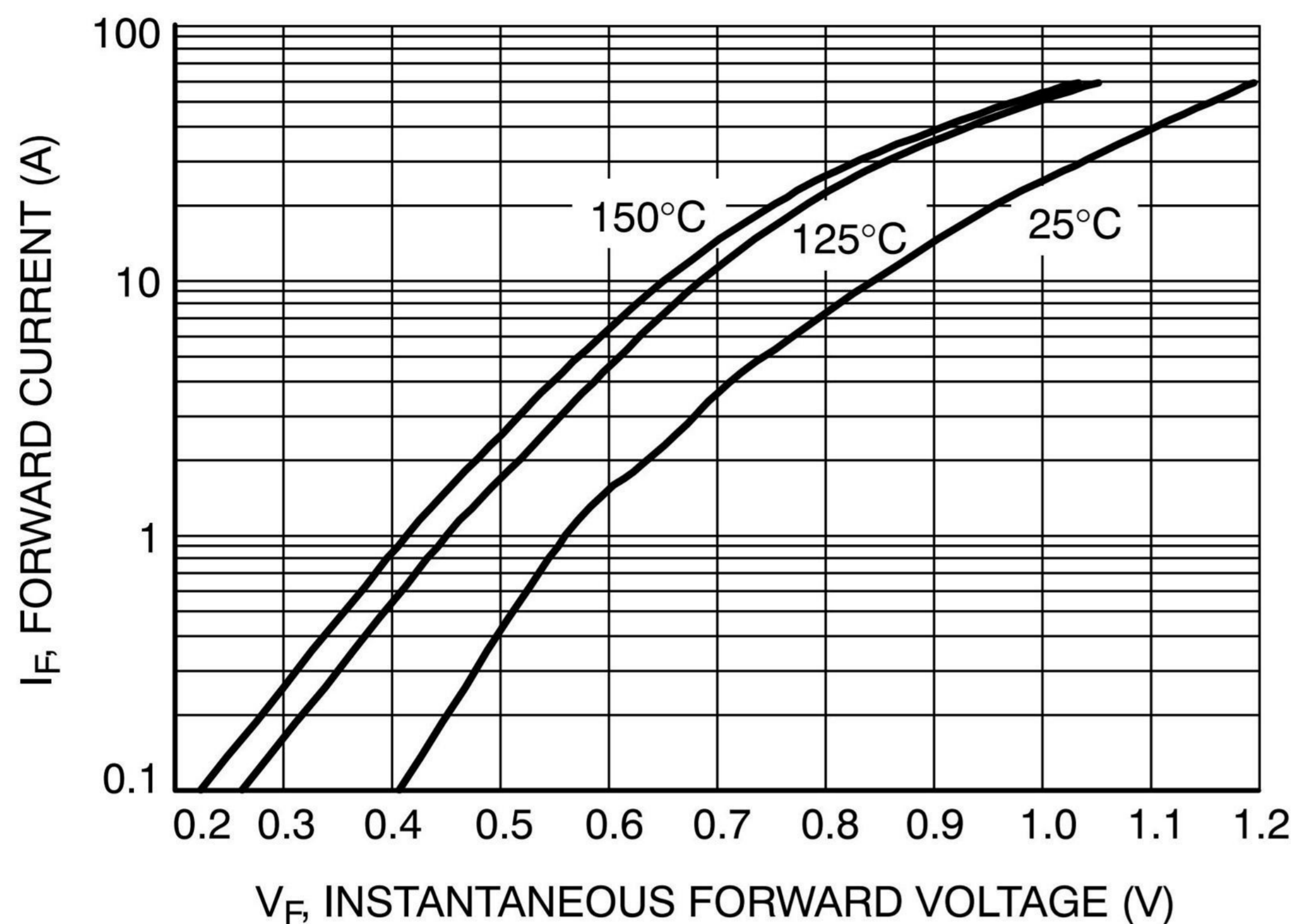

Figure 1. Typical Forward Voltage

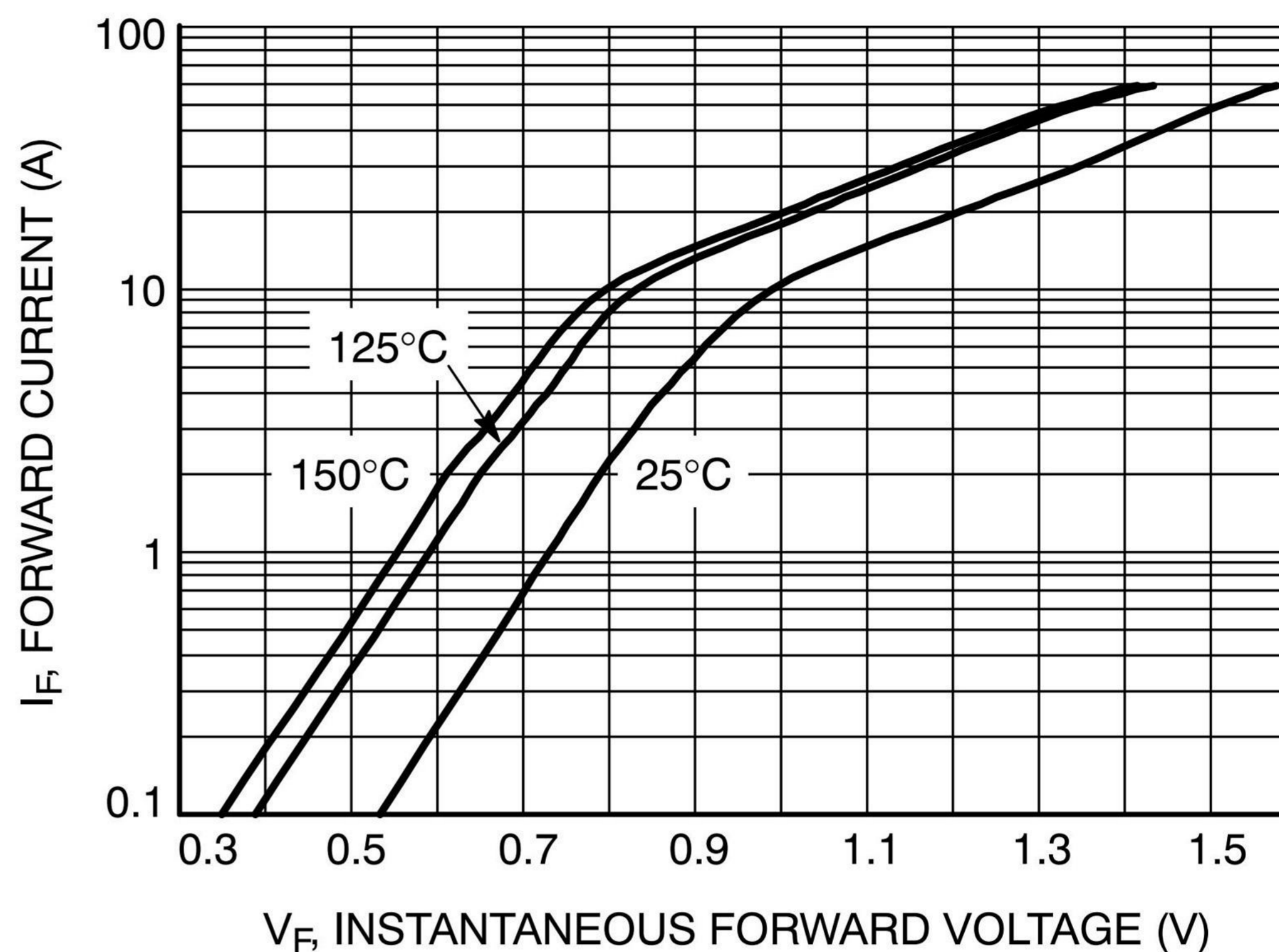

Figure 2. Maximum Forward Voltage

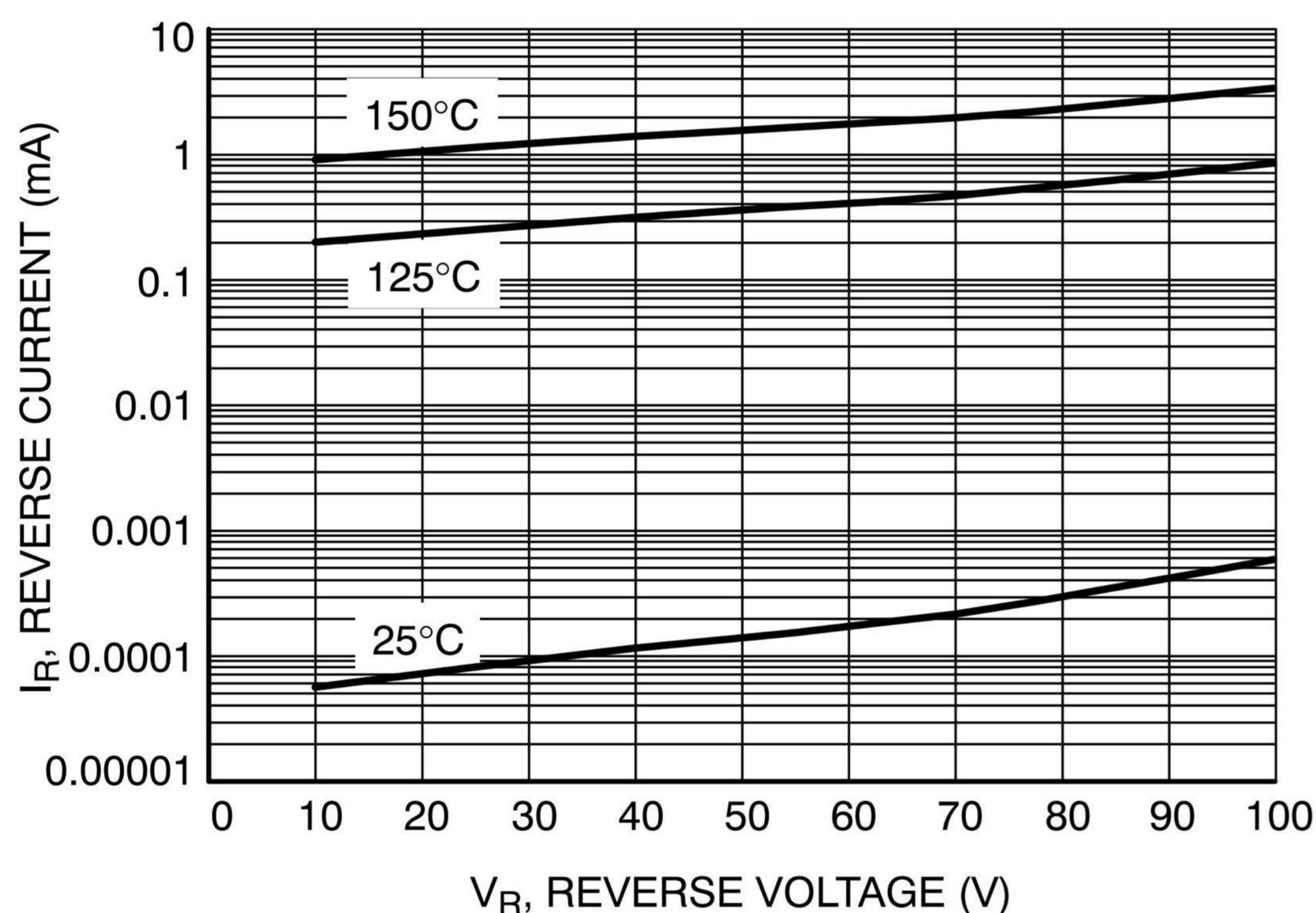

Figure 3. Typical Reverse Current

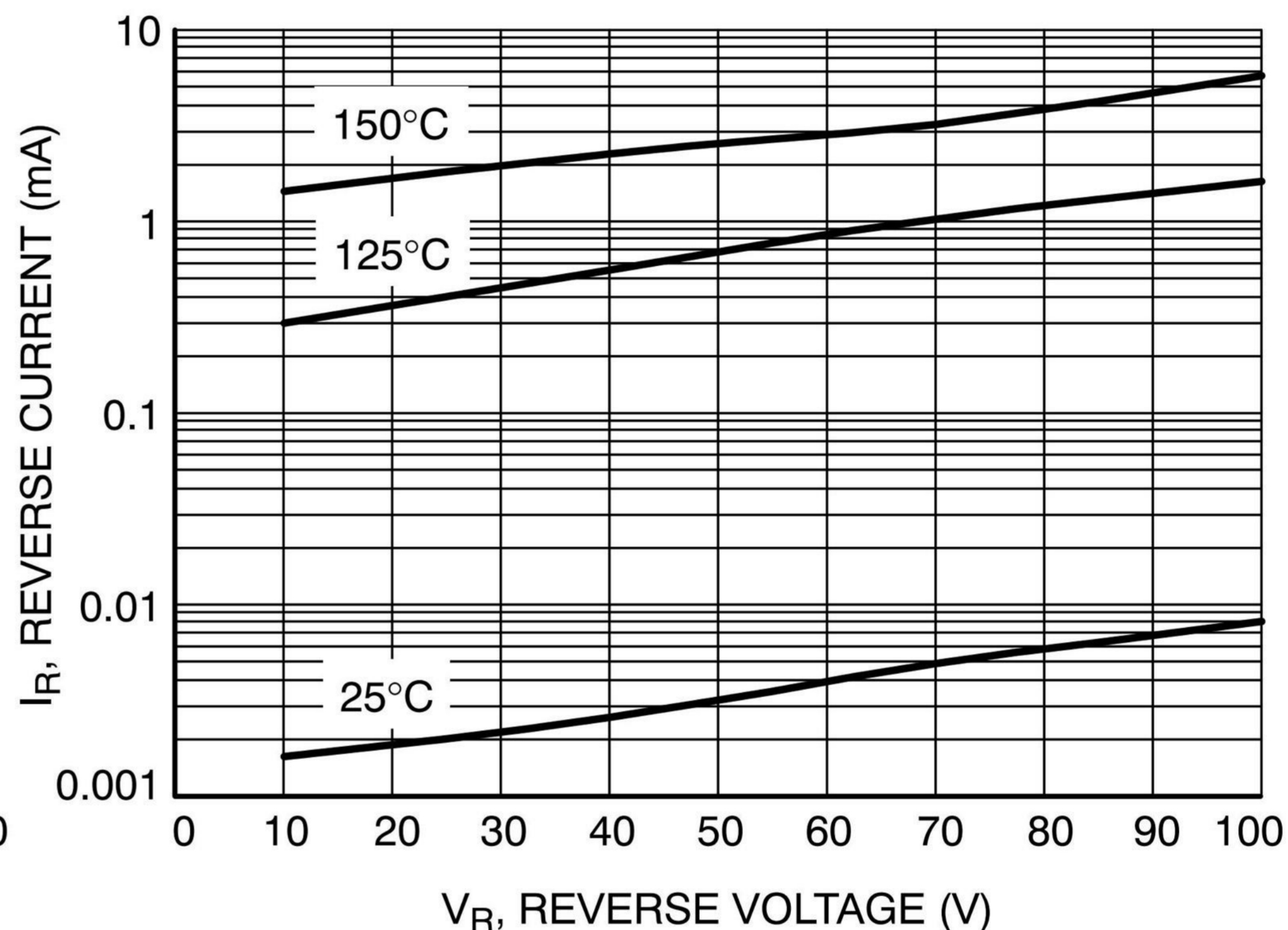

Figure 4. Maximum Reverse Current

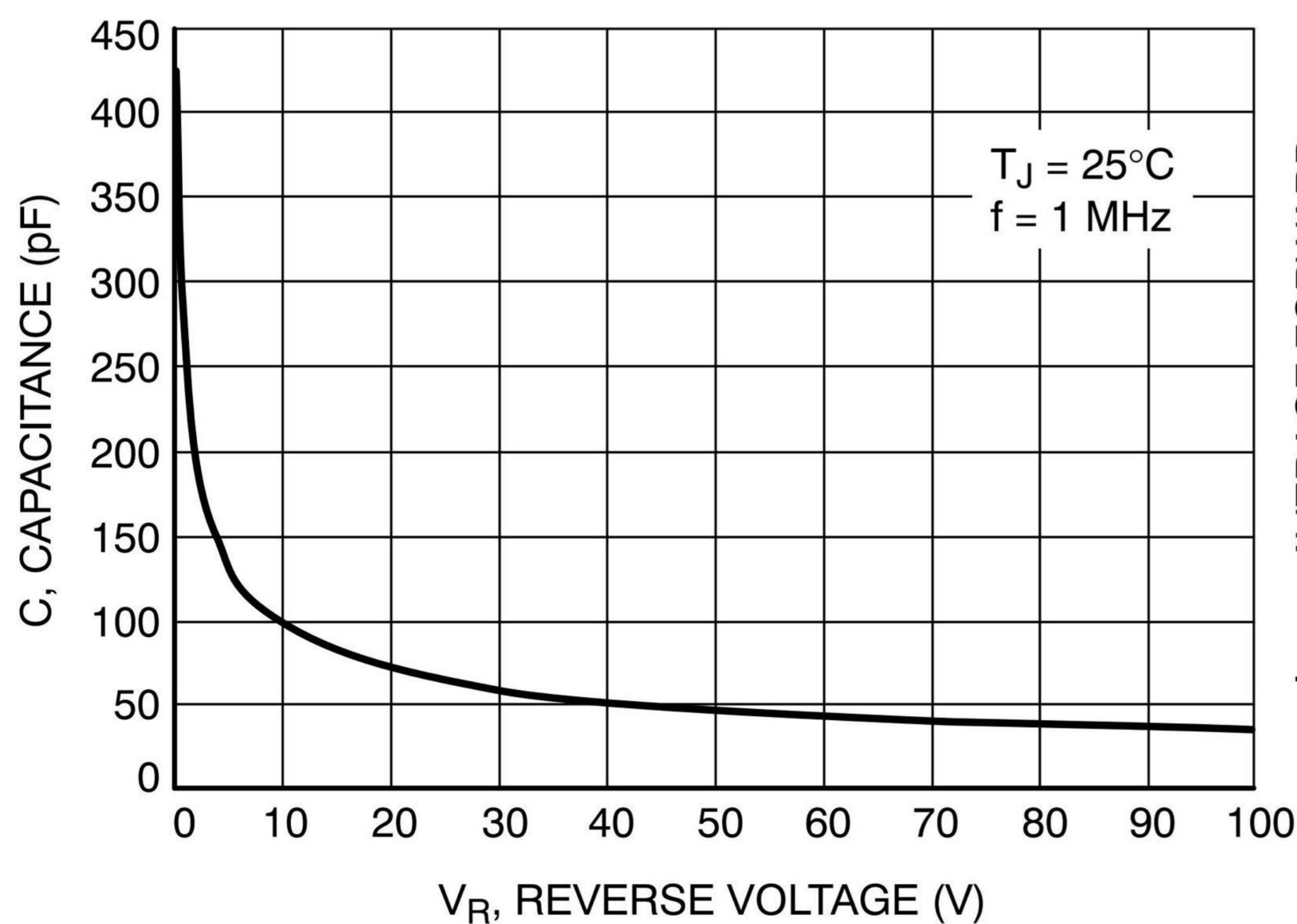

Figure 5. Typical Capacitance

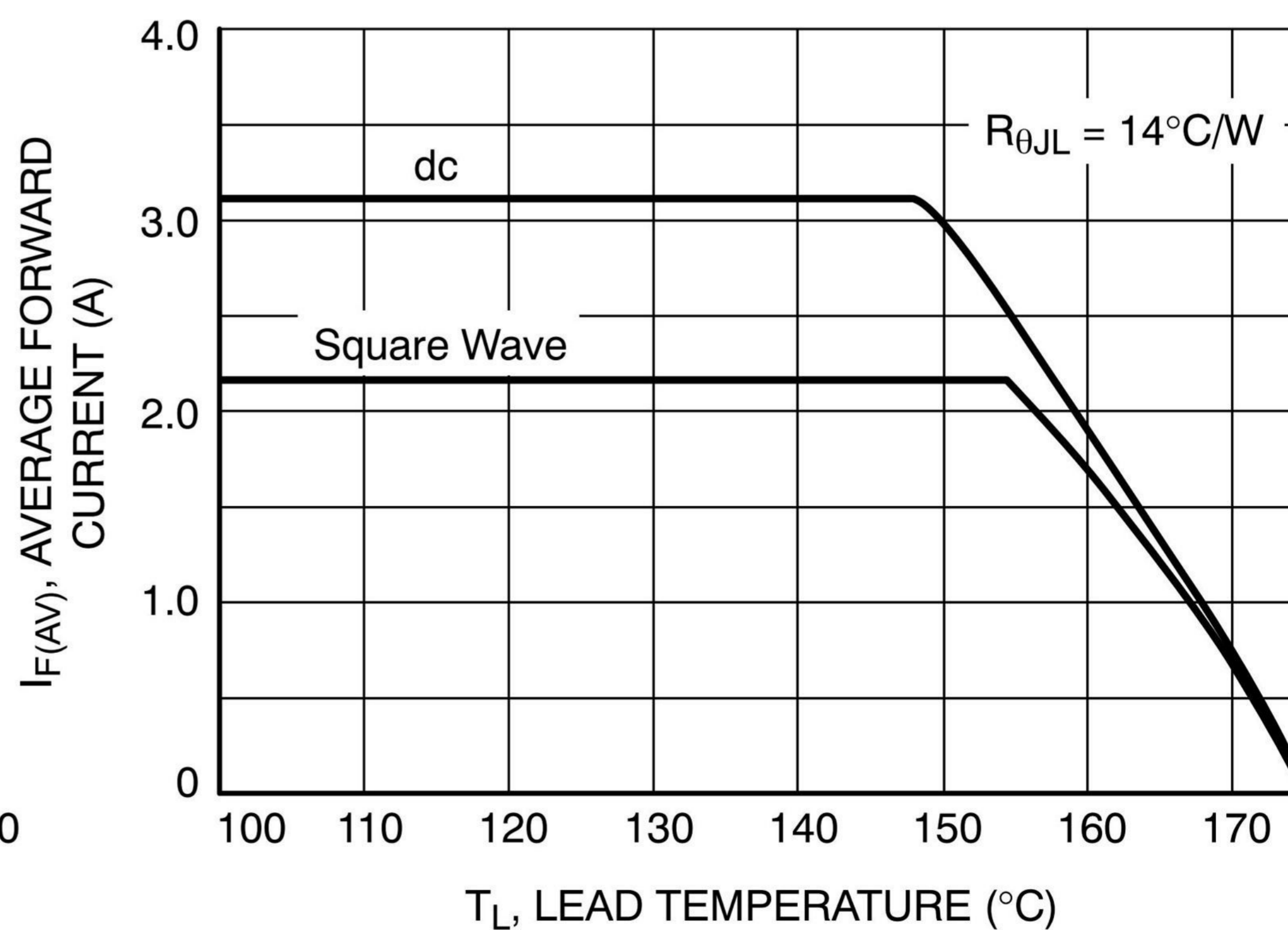

Figure 6. Current Derating - Lead

OM SENI

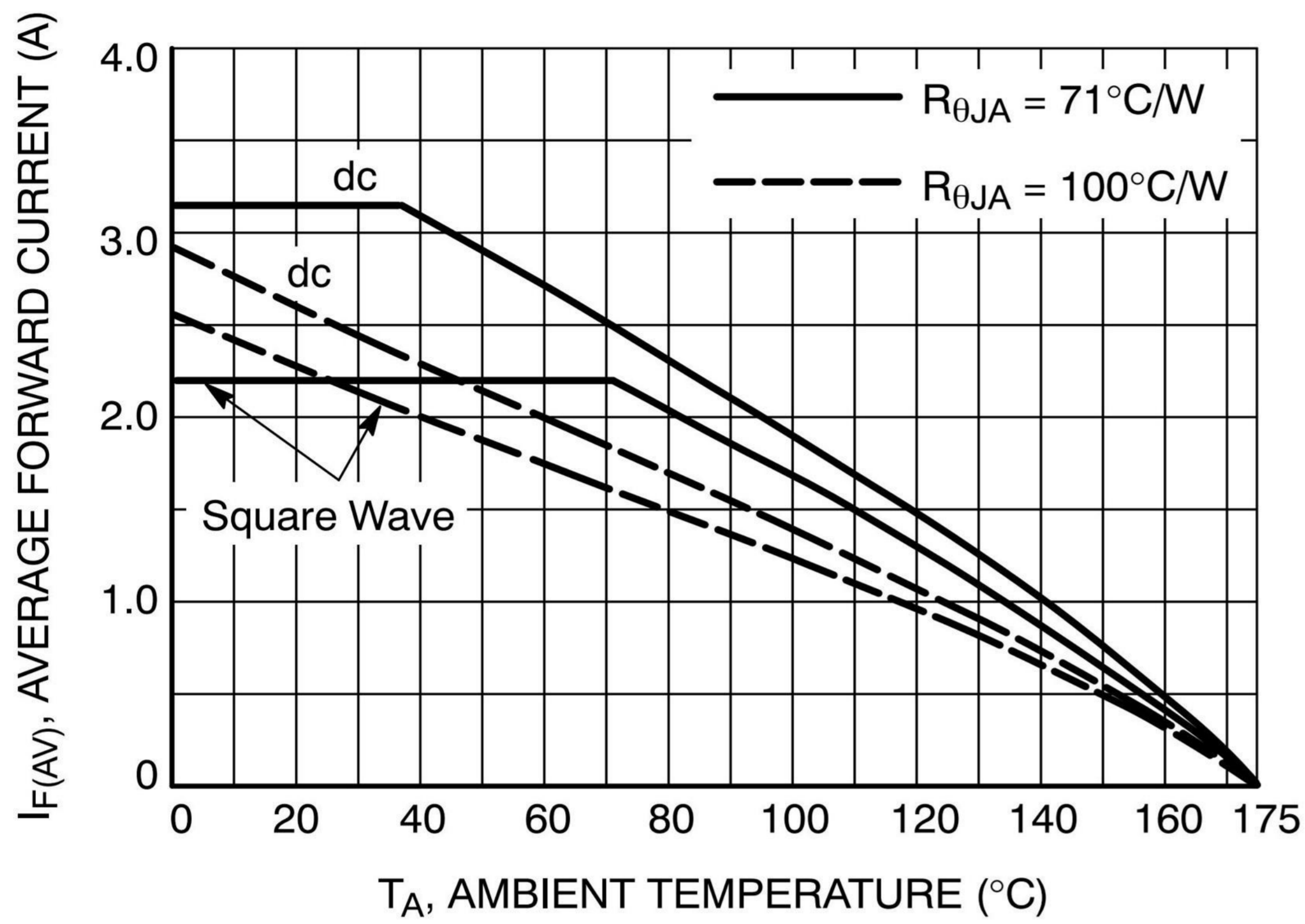

Figure 7. Current Derating, Ambient

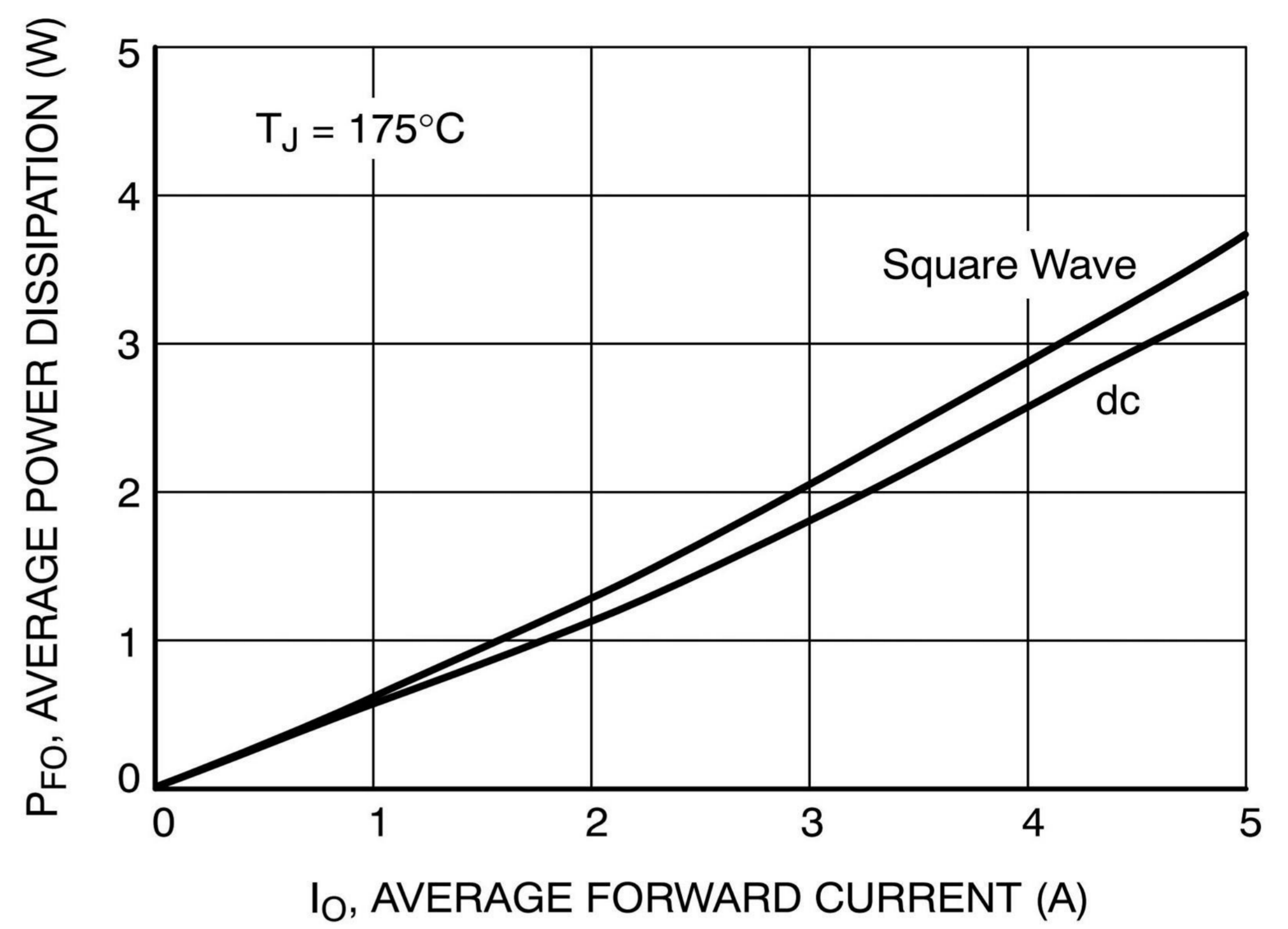

Figure 8. Maximum Forward Power Dissipation

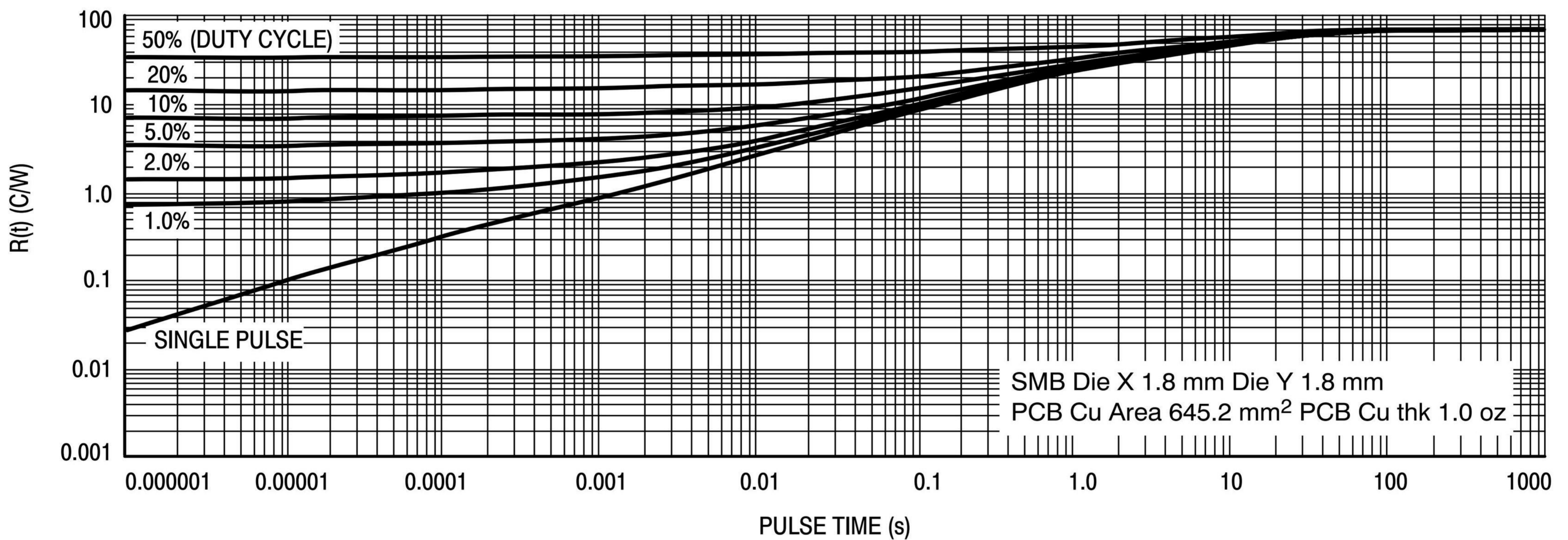
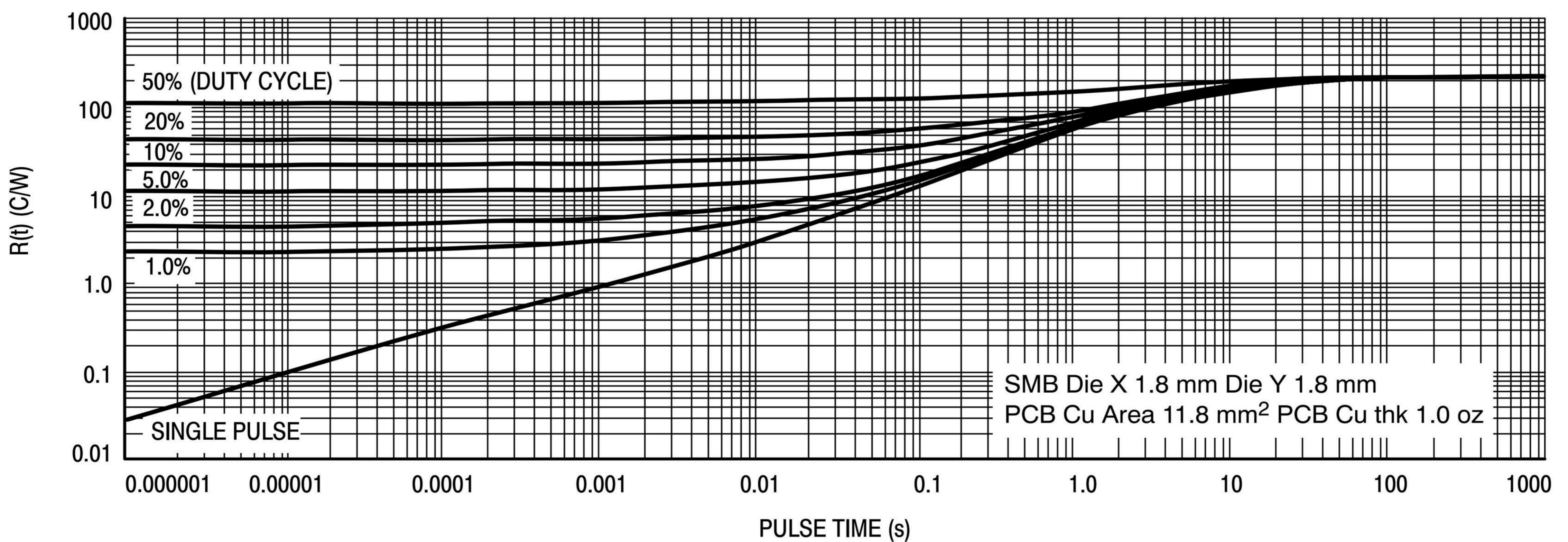

Figure 9. Thermal Response, Junction-to-Ambient (1 inch pad) - MBRS2H100T3G/NBRS2H100T3G



OM SENI

Ordering Information

PACKAGE	PACKAGE CODE	UNIT WEIGHT(g)	REEL(pcs)	BOX(pcs)	CARTON(pcs)	DELIVERY MODE
SMB	R3	0.098	2500	5000	25000	13

Package Outline Dimensions (SMB/DO-214AA)

Symbol	Dimensions			
	Millimeters		Inches	
	Min.	Max.	Min.	Max.
A	1.85	2.21	0.073	0.087
B	4.25	4.85	0.167	0.191
C	3.30	3.94	0.130	0.155
D	2.15	2.65	0.085	0.104
E	0.75	1.52	0.030	0.060
F	-	0.203	-	0.008
G	5.08	5.59	0.200	0.220
H	0.15	0.31	0.006	0.012

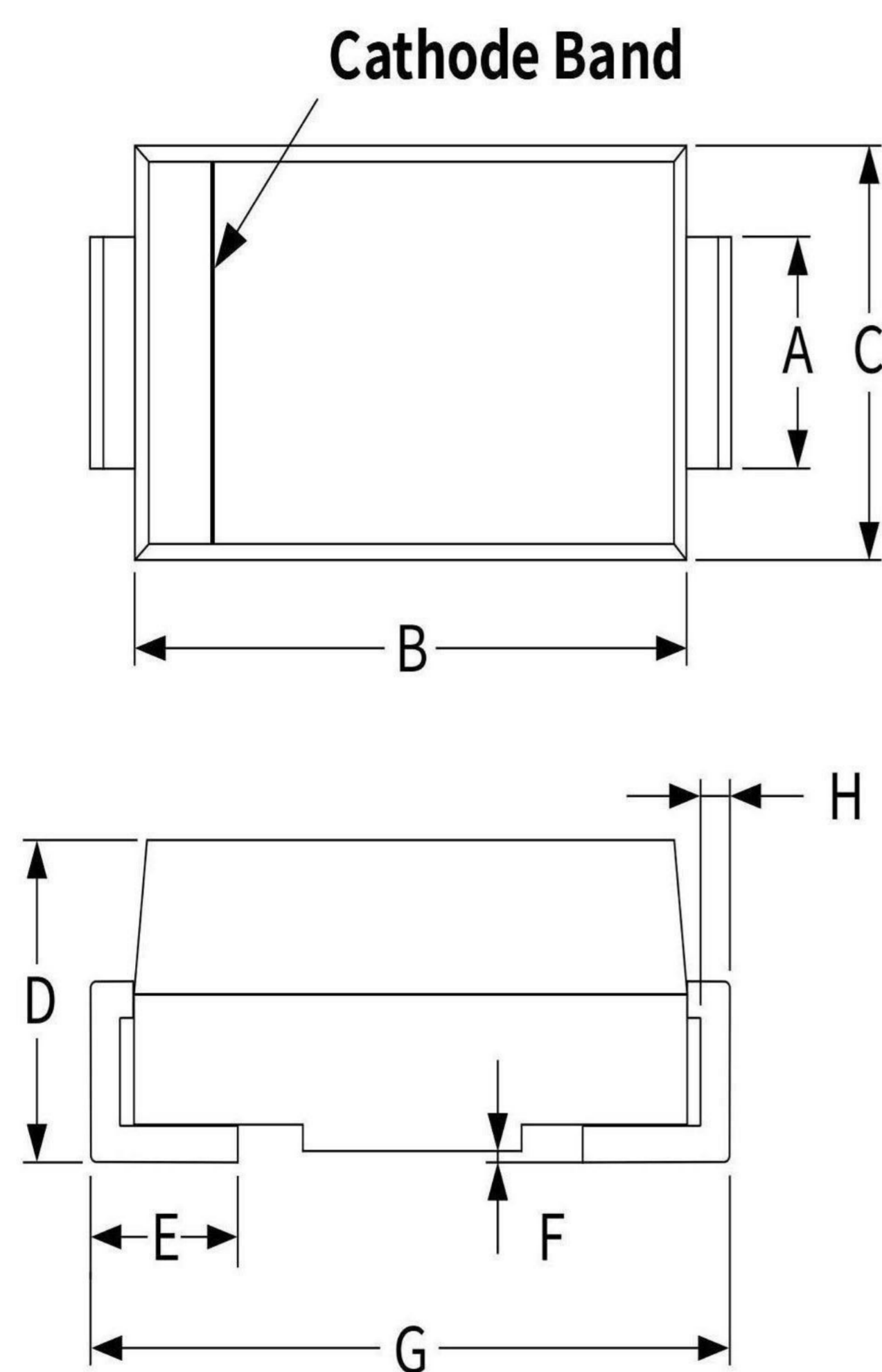

Suggested Pad Layout

Symbol	Dimensions			
	Millimeters		Inches	
	Min.	Max.	Min.	Max.
M	2.26	-	0.089	-
J	2.10	-	0.085	-
K	-	2.74	-	0.107

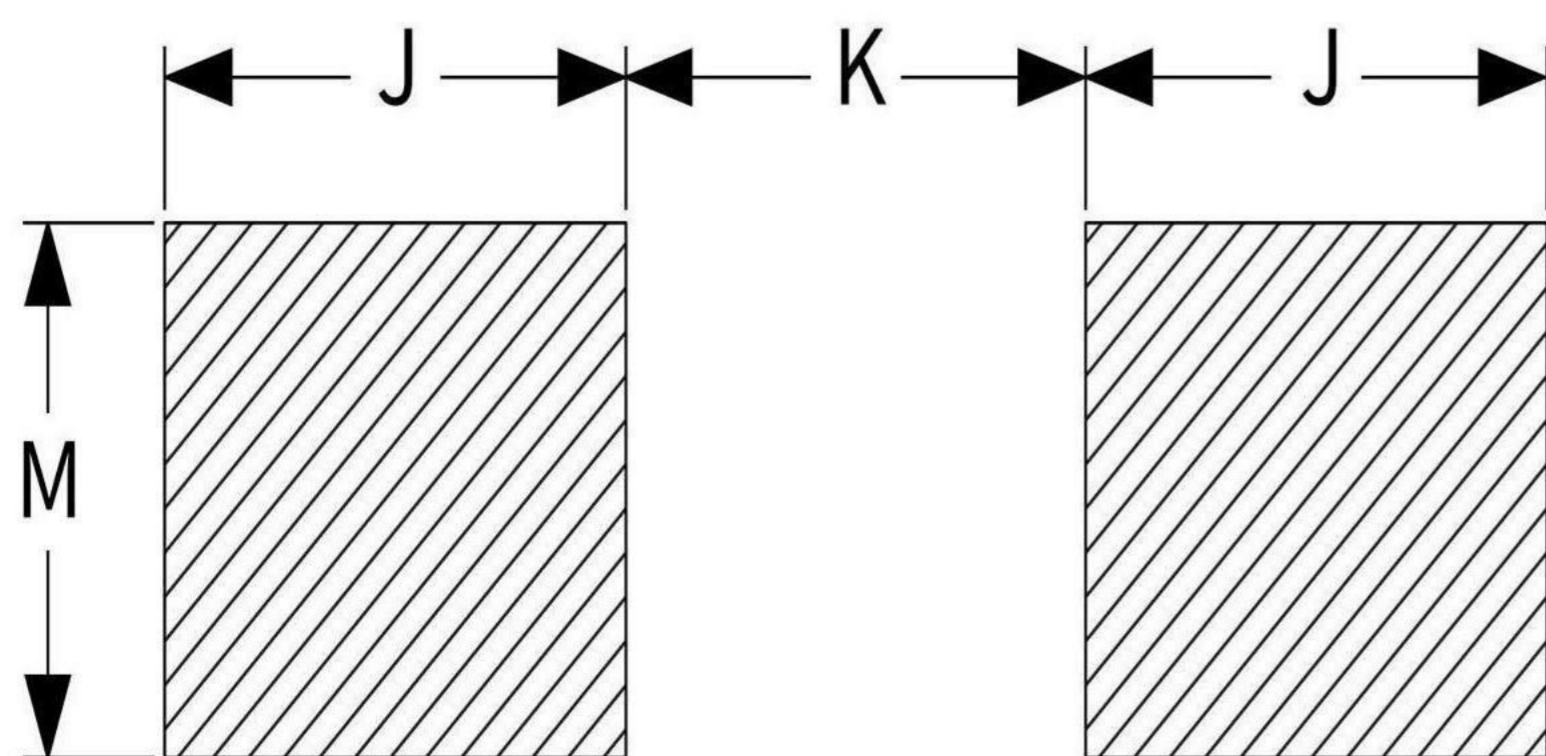

OM SENI

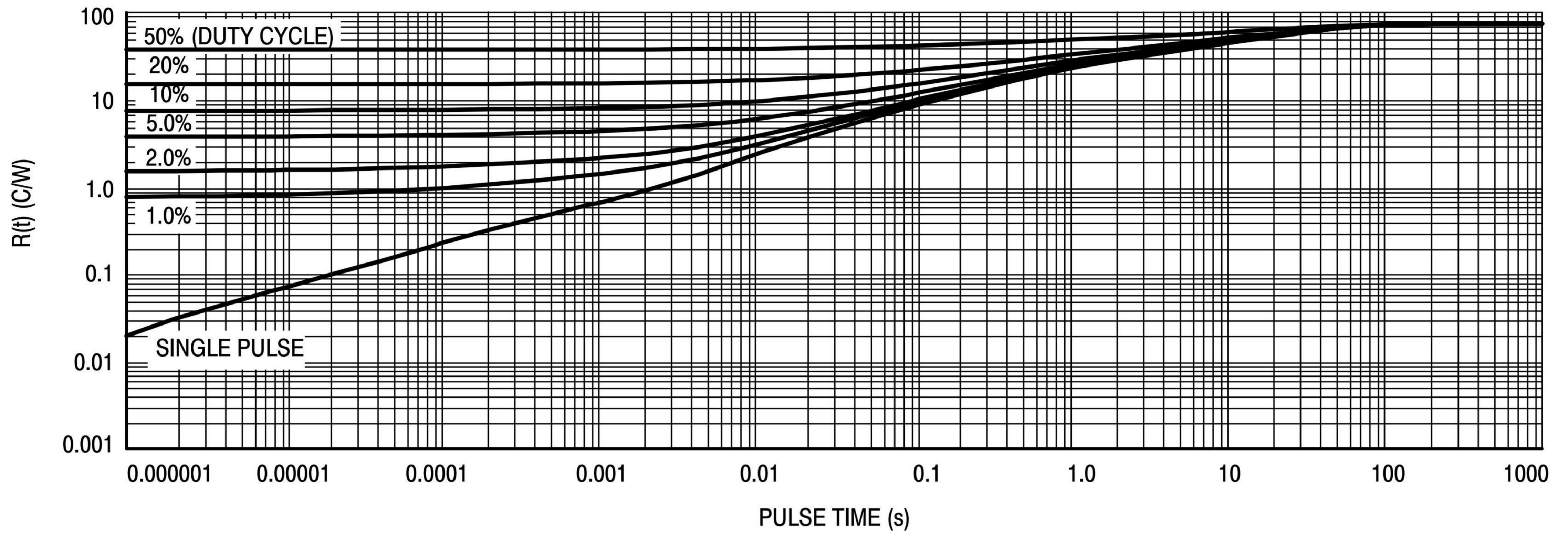

Figure 11. Thermal Response, Junction-to-Ambient (1 inch pad) - MBRA2H100T3G/NRVBA2H100T3G

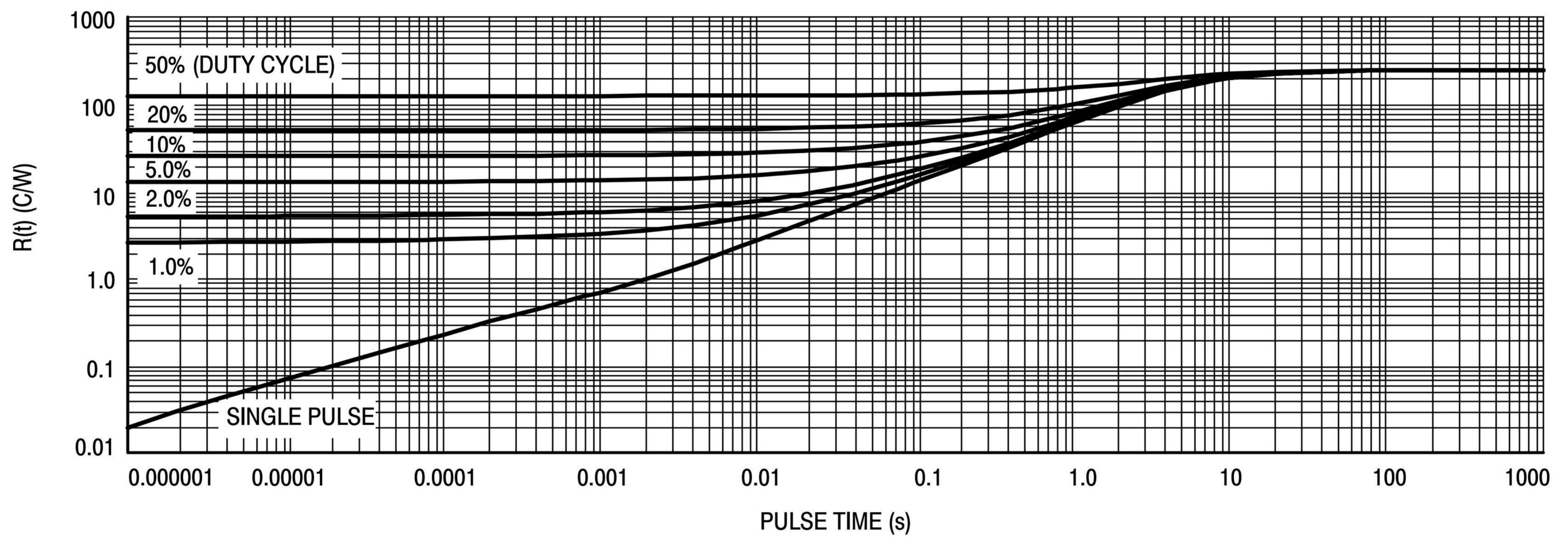
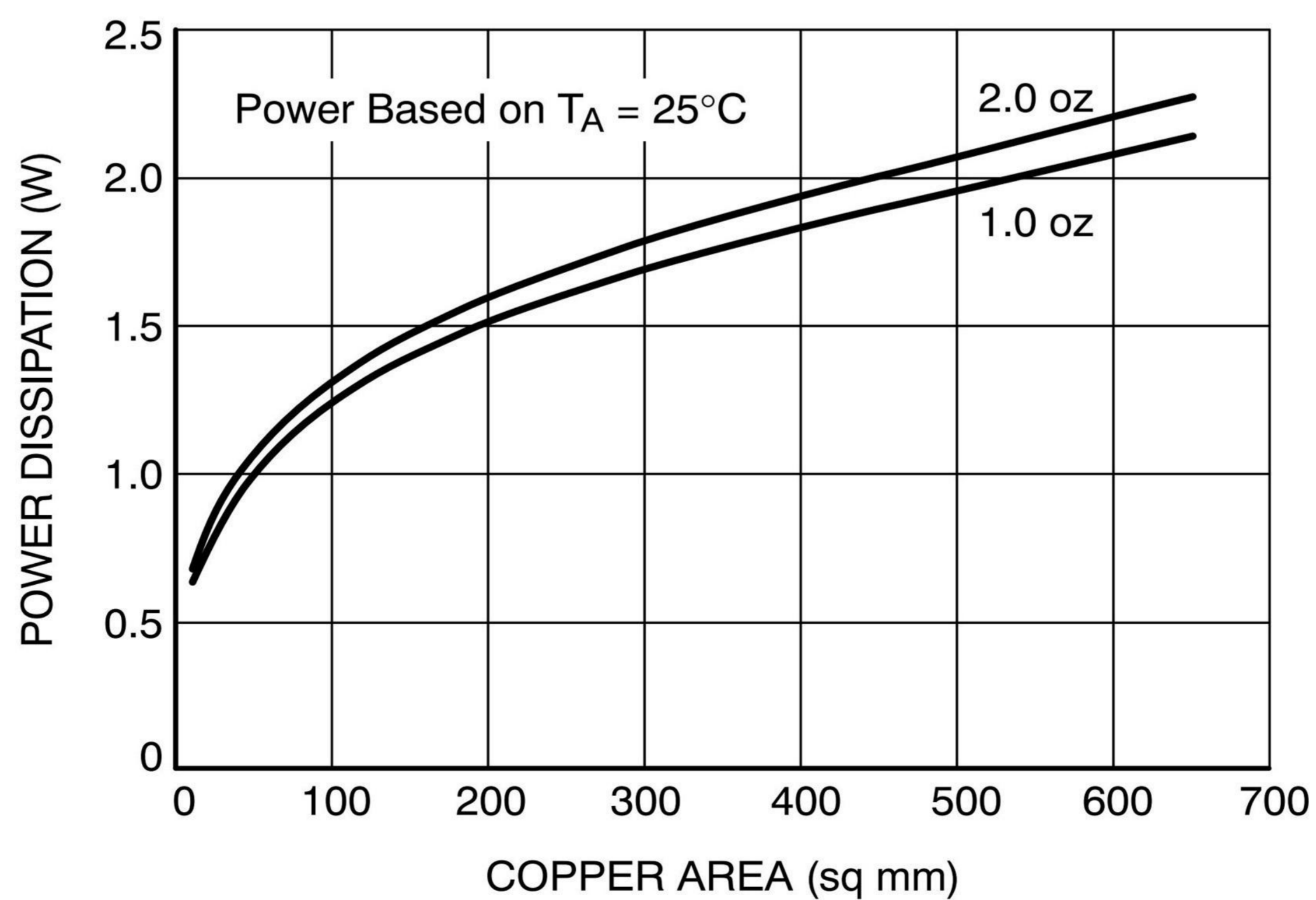

Figure 12. Thermal Response, Junction-to-Ambient (min pad) - MBRA2H100T3G/NRVBA2H100T3G



OM SENI

Ordering Information

PACKAGE	PACKAGE CODE	UNIT WEIGHT(g)	REEL(pcs)	BOX(pcs)	CARTON(pcs)	DELIVERY MODE
SMA	R2	0.07	5000	10000	80000	13"

Package Outline Dimensions (SMA/DO-214AC)

Symbol	Dimensions			
	Millimeters		Inches	
	Min.	Max.	Min.	Max.
A	1.25	1.65	0.049	0.065
B	3.95	4.65	0.156	0.183
C	2.35	2.85	0.093	0.112
D	1.98	2.41	0.078	0.095
E	0.76	1.52	0.030	0.060
F	-	0.203	-	0.008
G	4.70	5.30	0.185	0.209
H	0.15	0.31	0.006	0.012

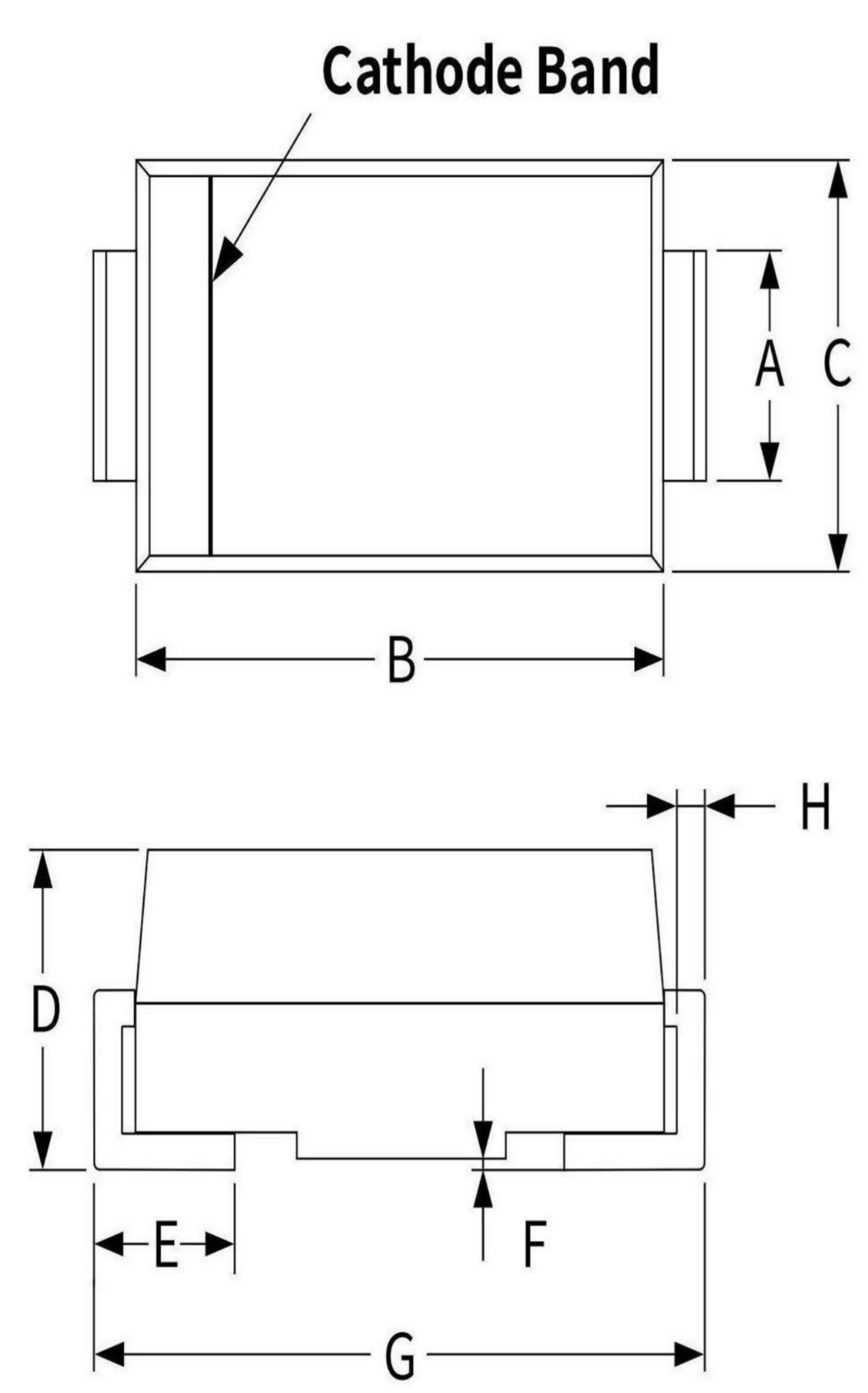

Suggested Pad Layout

Symbol	Dimensions			
	Millimeters		Inches	
	Min.	Max.	Min.	Max.
M	1.70	-	0.067	-
J	2.10	-	0.082	-
K	-	2.30	-	0.090

