

OM SENI

**MBRS320T3G, MBRS330T3G,
MBRS340T3G, MBRS360T3G,
MBRS320BT3G, MBRS330BT3G
MBRS340BT3G, MBRS360BT3G**

Surface Mount Schottky Power Rectifier

This device employs the Schottky Barrier principle in a large area metal-to-silicon power diode. State-of-the-art geometry features epitaxial construction with oxide passivation and metal overlay contact. Ideally suited for low voltage, high frequency rectification, or as free wheeling and polarity protection diodes, in surface mount applications where compact size and weight are critical to the system.

Features

- Small Compact Surface Mountable Package with J-Bend Leads
- Rectangular Package for Automated Handling
- Highly Stable Oxide Passivated Junction
- Excellent Ability to Withstand Reverse Avalanche Energy Transients
- Guard-Ring for Stress Protection
- These are Pb-Free Devices

Mechanical Characteristics

- Weight: 217 mg (Approximately), SMC
95 mg (Approximately), SMB
- Finish: All External Surfaces Corrosion Resistant and Terminal Leads are Readily Solderable
- Lead and Mounting Surface Temperature for Soldering Purposes: 260°C Max. for 10 Seconds
- Polarity: Notch in Plastic Body Indicates Cathode Lead
- Device Meets MSL 1 Requirements
- ESD Ratings:
 - ◆ Machine Model, C
 - ◆ Human Body Model, 3B

SCHOTTKY BARRIER RECTIFIERS

3.0 AMPERES, 20-60 VOLTS

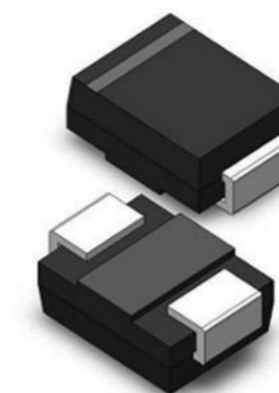

**SMC
CASE 403**

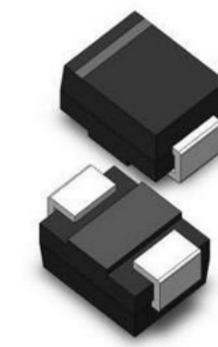

**SMB
CASE 403A**

MARKING DIAGRAMS

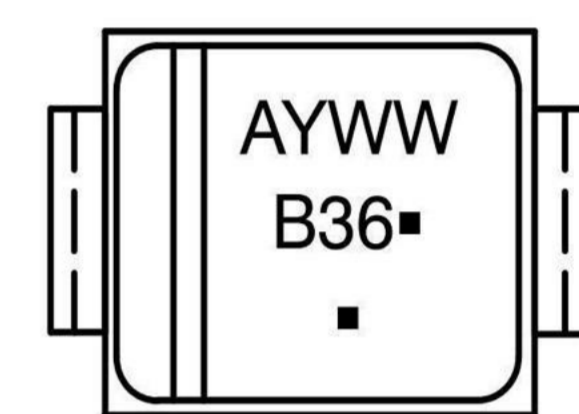
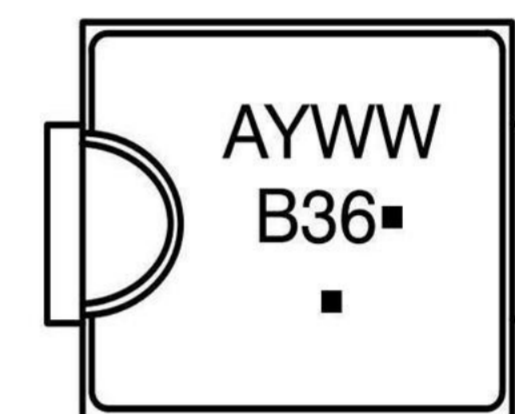

- B36 = Specific Device Code
A = Assembly Location
Y = Year
WW = Work Week
▪ = Pb-Free Package
(Note: Microdot may be in either location)

ORDERING INFORMATION

Device	MARKING	Package	Shipping [†]
MBRS320T3G	B32	SMC (Pb-Free)	2,500 / Tape & Reel
MBRS330T3G	B33	SMC (Pb-Free)	2,500 / Tape & Reel
MBRS340T3G	B34	SMC (Pb-Free)	2,500 / Tape & Reel
MBRS360T3G	B36	SMC (Pb-Free)	2,500 / Tape & Reel
MBRS320BT3G	B32	SMB (Pb-Free)	2,500 / Tape & Reel
MBRS330BT3G	B33	SMB (Pb-Free)	2,500 / Tape & Reel
MBRS340BT3G	B34	SMB (Pb-Free)	2,500 / Tape & Reel
MBRS360BT3G	B36	SMB (Pb-Free)	2,500 / Tape & Reel

[†]For information on tape and reel specifications, including part orientation and tape sizes, please refer to our Tape and Reel Packaging Specification Brochure, BRD8011/D.

OM SENI

MAXIMUM RATINGS

Rating	Symbol	Value	Unit
Peak Repetitive Reverse Voltage Working Peak Reverse Voltage DC Blocking Voltage	V_{RRM} V_{RWM} V_R	60	V
Average Rectified Forward Current	$I_{F(AV)}$	3.0 @ $T_L = 137^\circ\text{C}$ 4.0 @ $T_L = 127^\circ\text{C}$	A
Nonrepetitive Peak Surge Current (Surge applied at rated load conditions halfwave, single phase, 60 Hz)	I_{FSM}	125	A
Storage Temperature Range	T_{stg}	- 65 to +175	$^\circ\text{C}$
Operating Junction Temperature (Note 1)	T_J	- 65 to +175	$^\circ\text{C}$

Stresses exceeding those listed in the Maximum Ratings table may damage the device. If any of these limits are exceeded, device functionality should not be assumed, damage may occur and reliability may be affected.

1. The heat generated must be less than the thermal conductivity from Junction-to-Ambient: $dP_D/dT_J < 1/R_{\theta JA}$.

THERMAL CHARACTERISTICS

Characteristic	Symbol	Value	Unit
Thermal Resistance, Junction-to-Lead (Note 2) SMC Package SMB Package	$R_{\theta JL}$	11 15	$^\circ\text{C/W}$
Thermal Resistance, Junction-to-Ambient (Note 2) SMC Package SMB Package	$R_{\theta JA}$	136 145	$^\circ\text{C/W}$
Thermal Resistance, Junction-to-Ambient (Note 3) SMC Package SMB Package (Note 4)	$R_{\theta JA}$	71 73	$^\circ\text{C/W}$

ELECTRICAL CHARACTERISTICS

Maximum Instantaneous Forward Voltage (Note 5) ($i_F = 3.0\text{ A}$, $T_J = 25^\circ\text{C}$)	V_F	0.63	V
Maximum Instantaneous Reverse Current (Note 5) (Rated dc Voltage, $T_J = 25^\circ\text{C}$) (Rated dc Voltage, $T_J = 100^\circ\text{C}$)	i_R	0.03 3.0	mA

Product parametric performance is indicated in the Electrical Characteristics for the listed test conditions, unless otherwise noted. Product performance may not be indicated by the Electrical Characteristics if operated under different conditions.

- Mounted with minimum recommended pad size, PC Board FR4.
- 1 inch square pad size (1 x 0.5 inch for each lead) on FR4 board.
- Typical Value; 1 inch square pad size (1 x 0.5 inch for each lead) on FR4 board.
- Pulse Test: Pulse Width = 300 μs , Duty Cycle $\leq 2.0\%$.

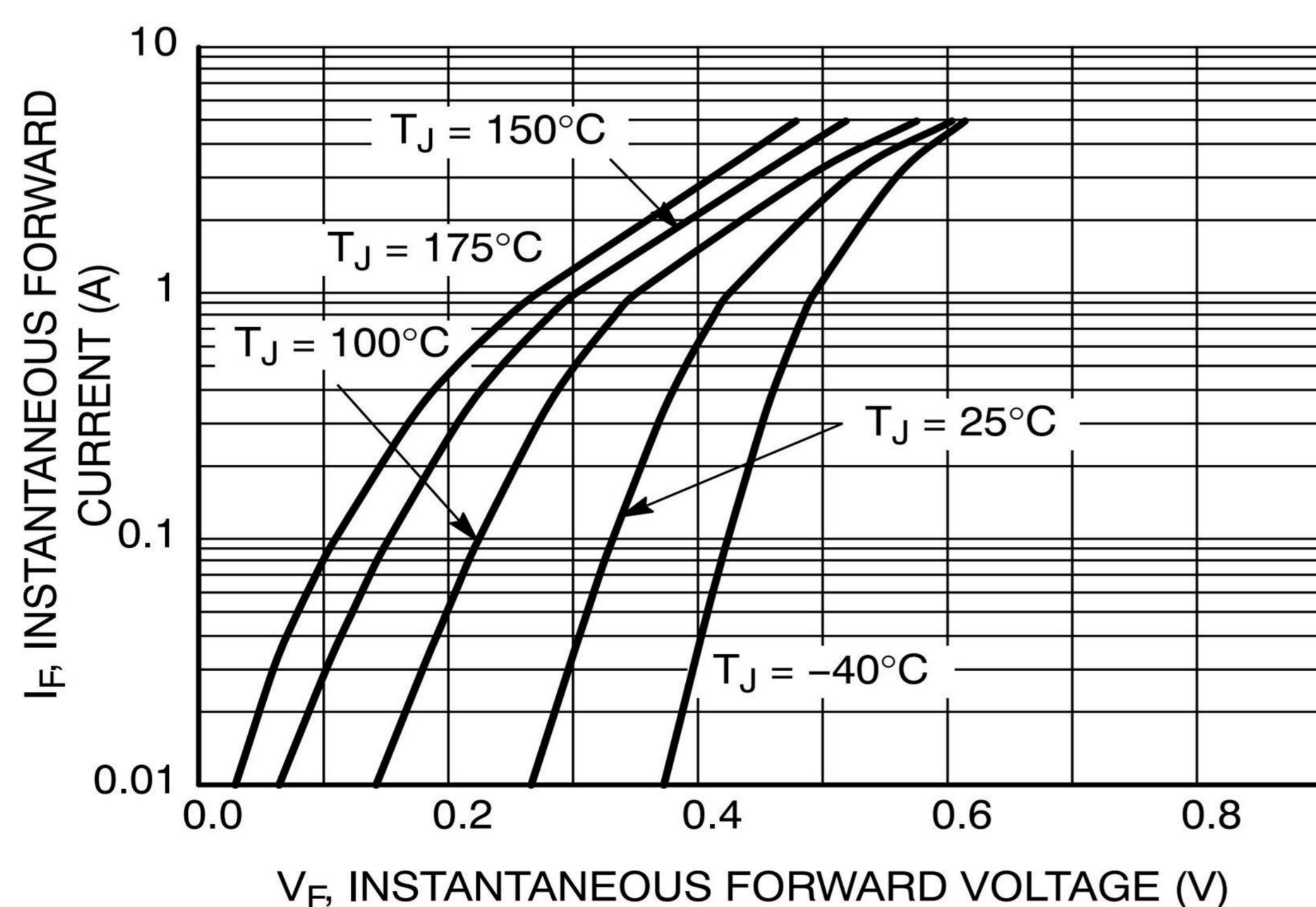

Figure 1. Typical Forward Voltage

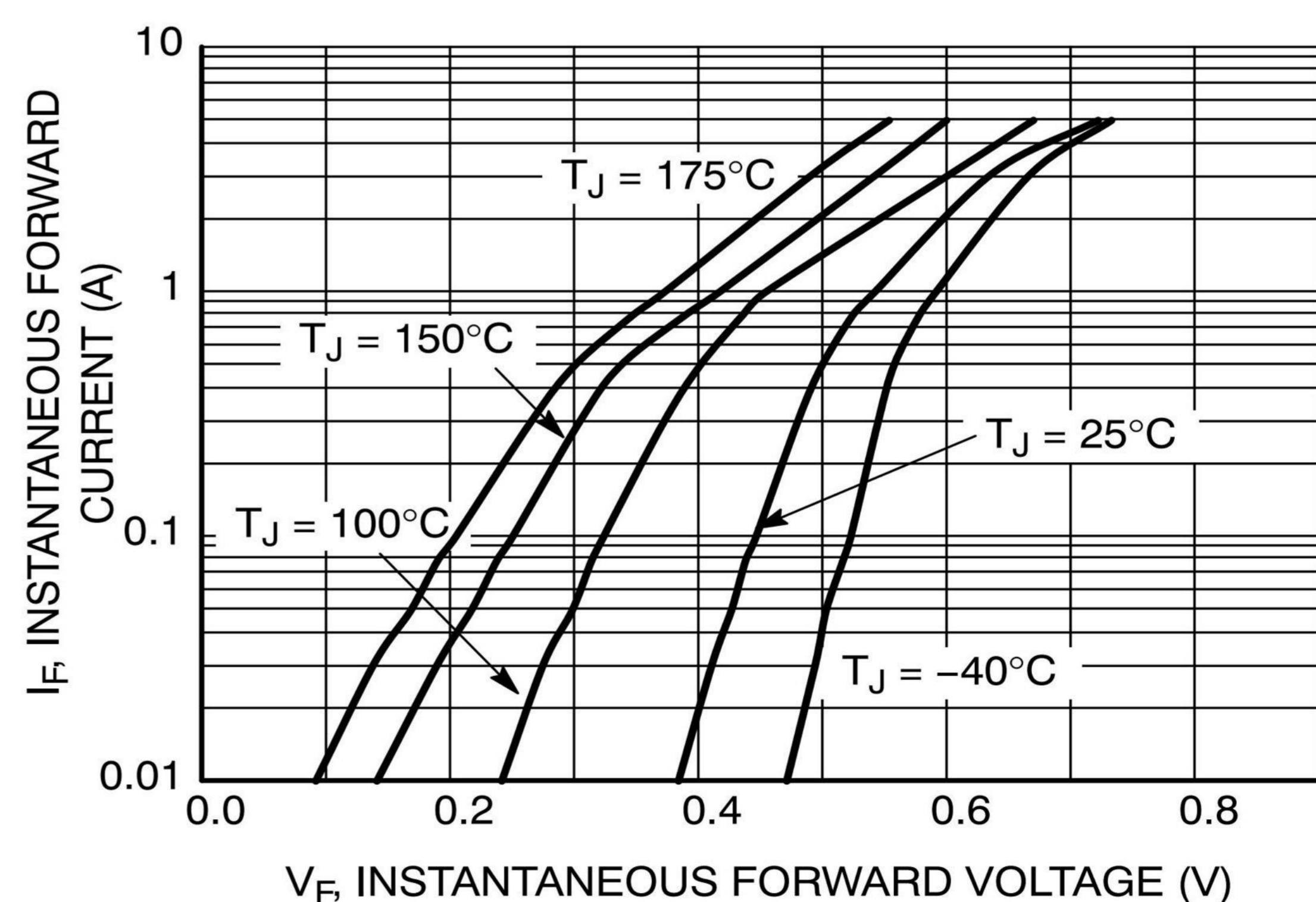

Figure 2. Maximum Forward Voltage

OM SENI

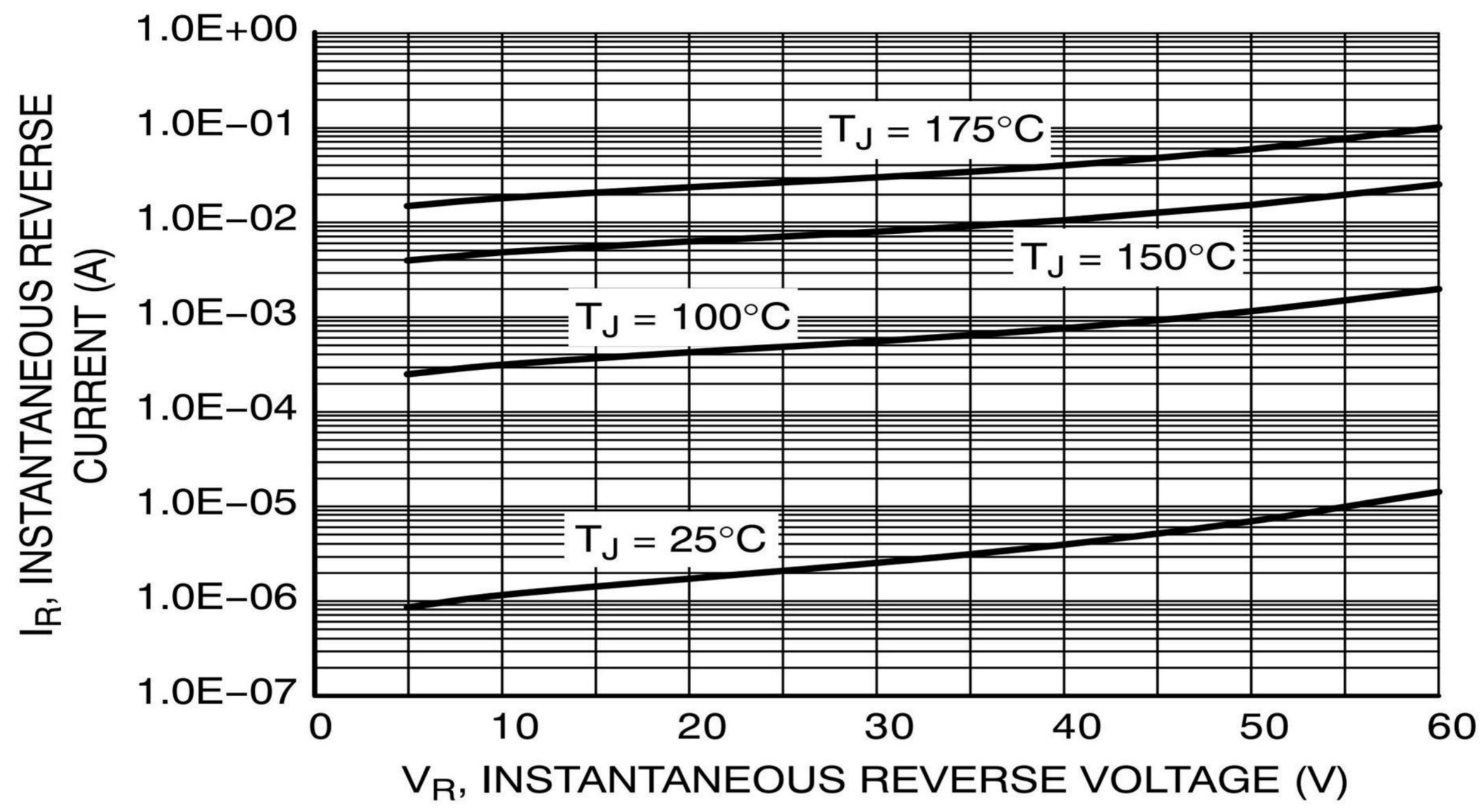

Figure 3. Typical Reverse Current

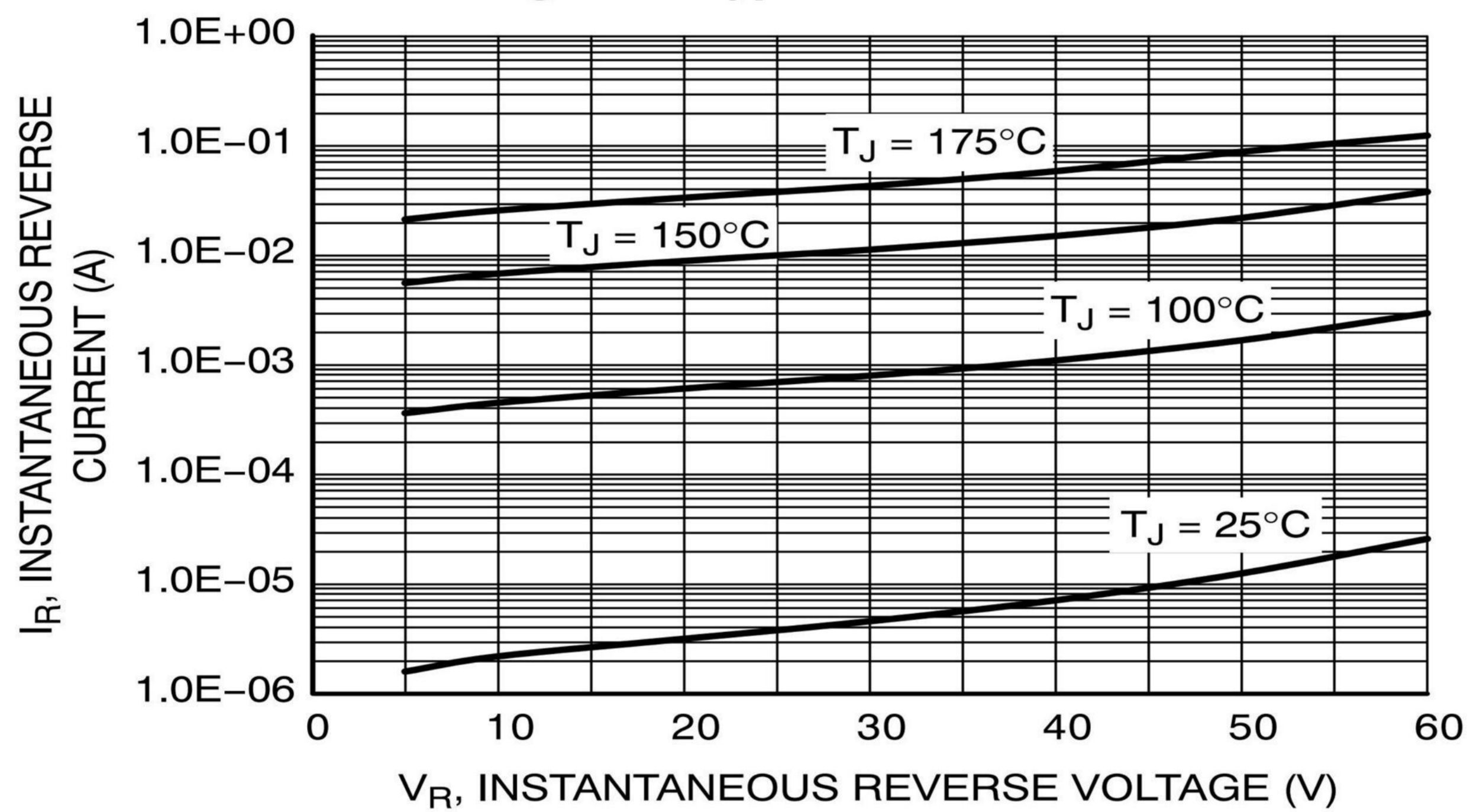

Figure 4. Maximum Reverse Current

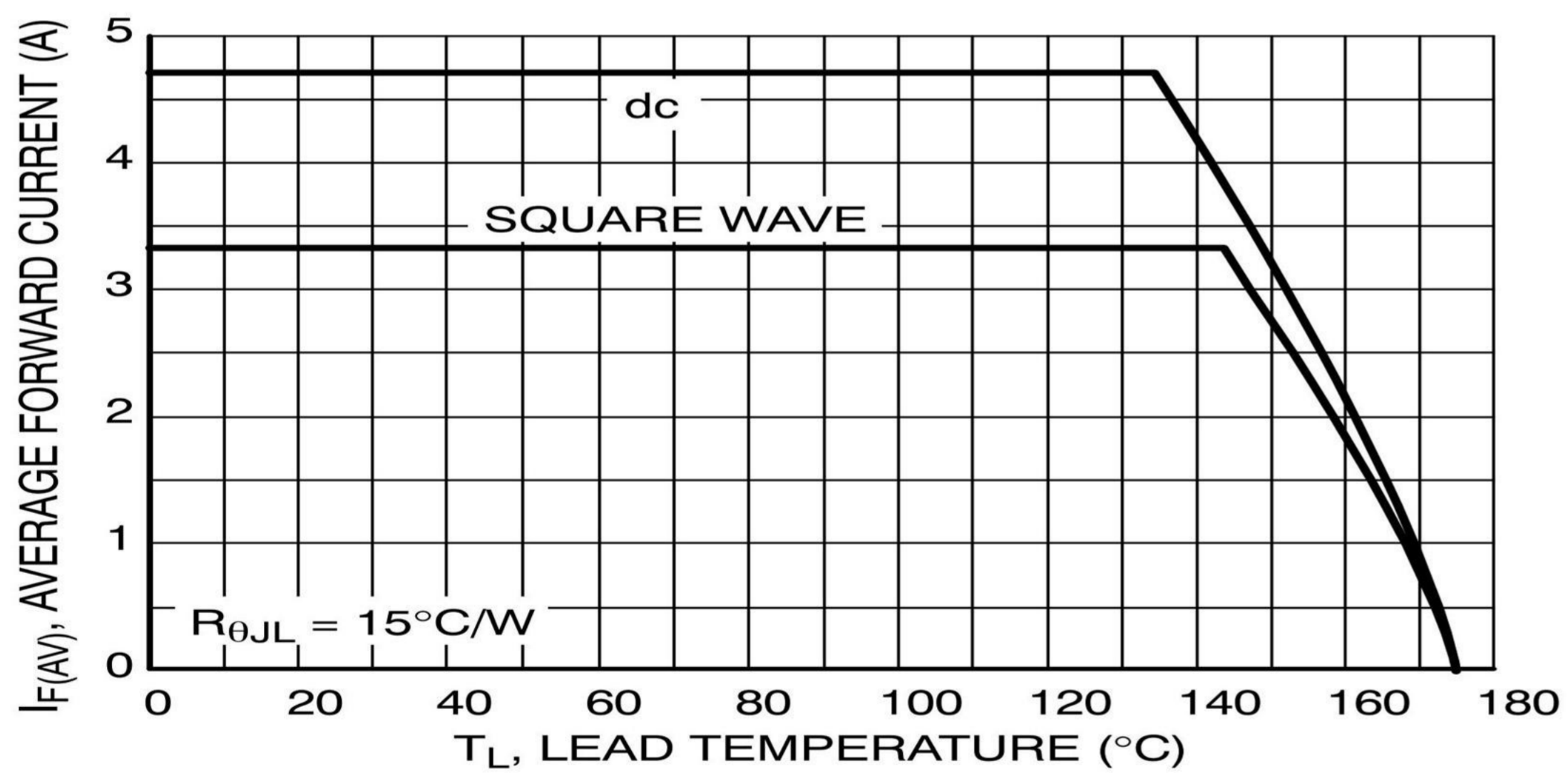

Figure 5. Current Derating

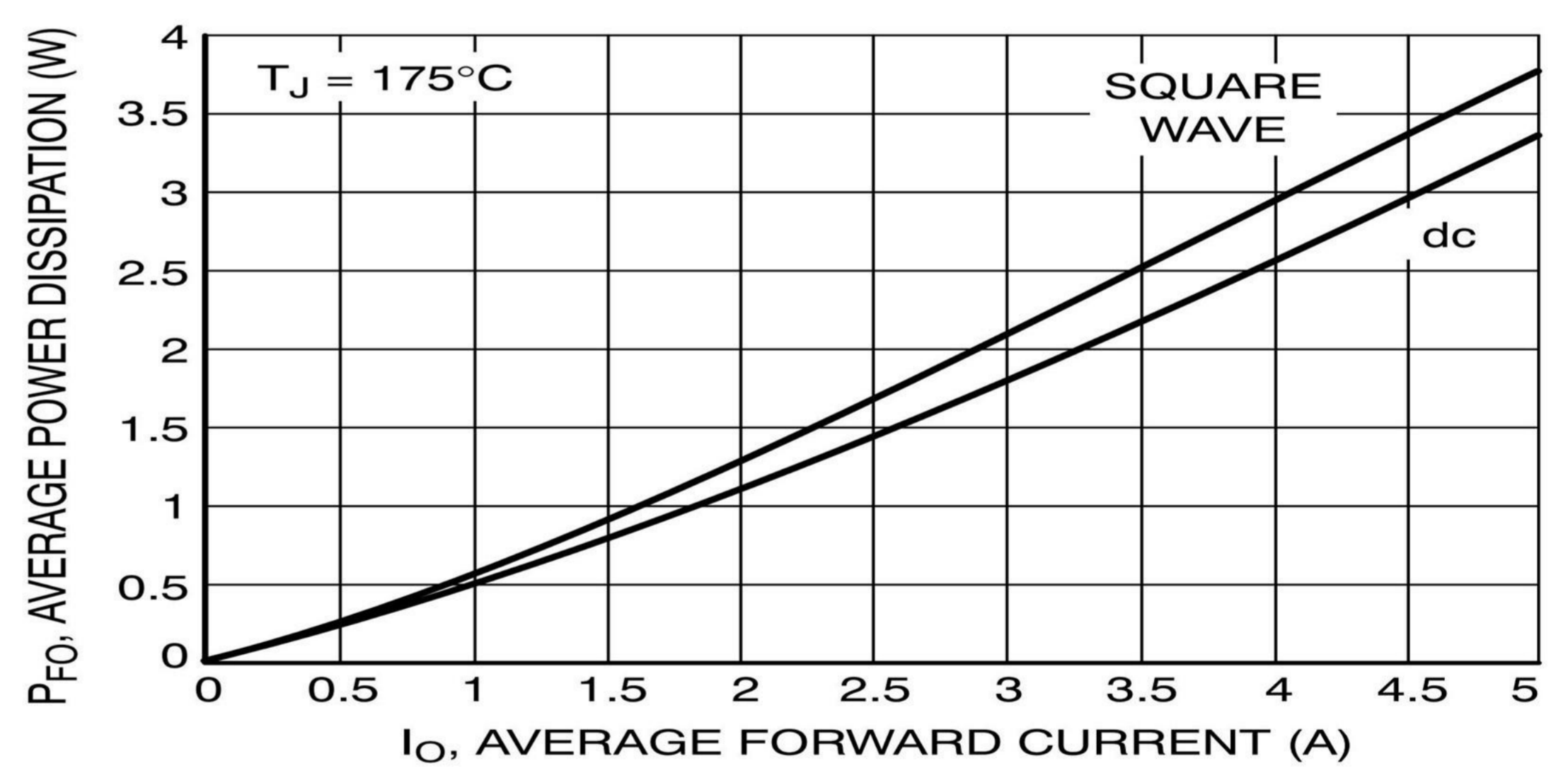

Figure 6. Forward Power Dissipation

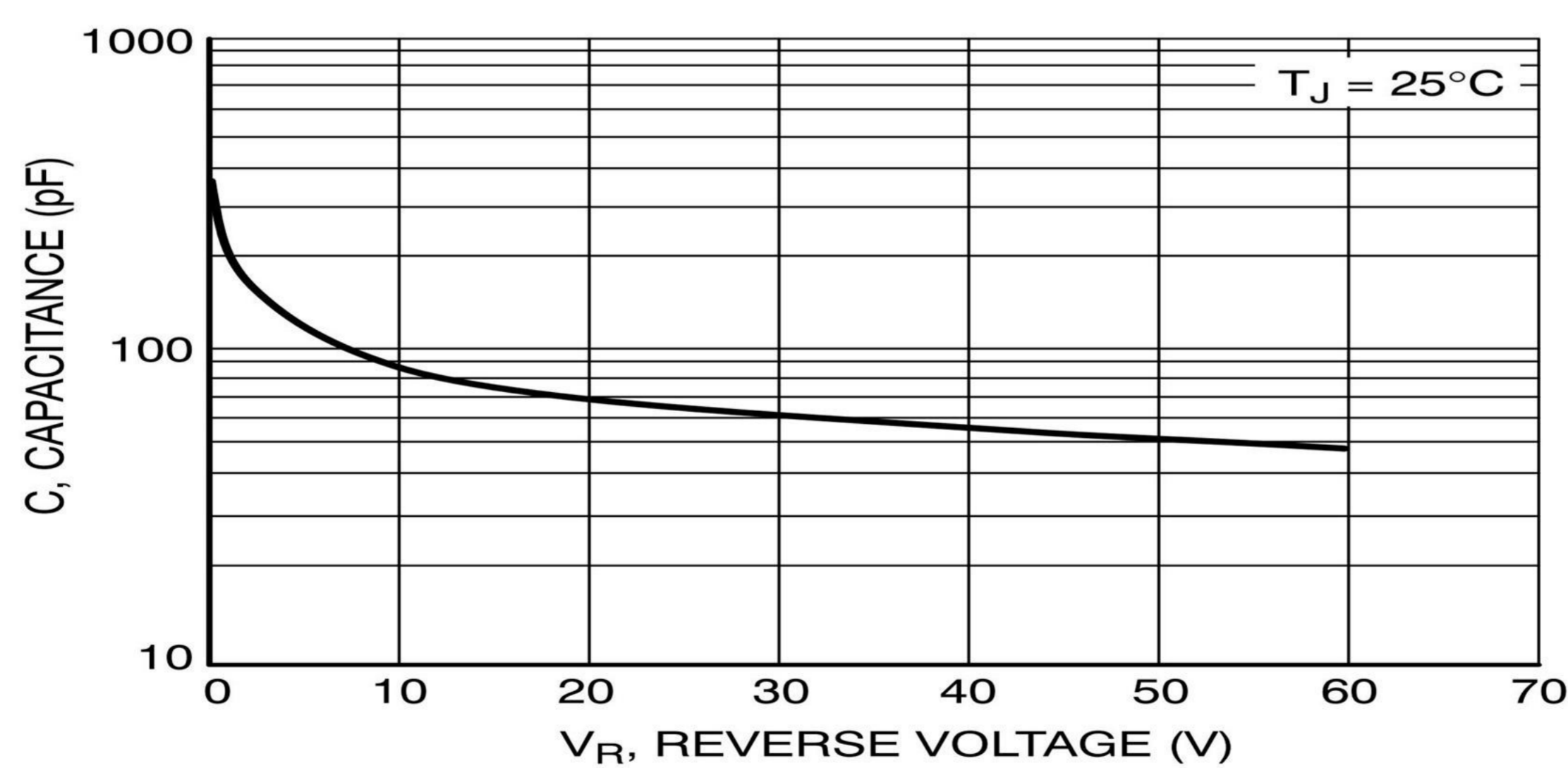

Figure 7. Typical Capacitance

OM SENI

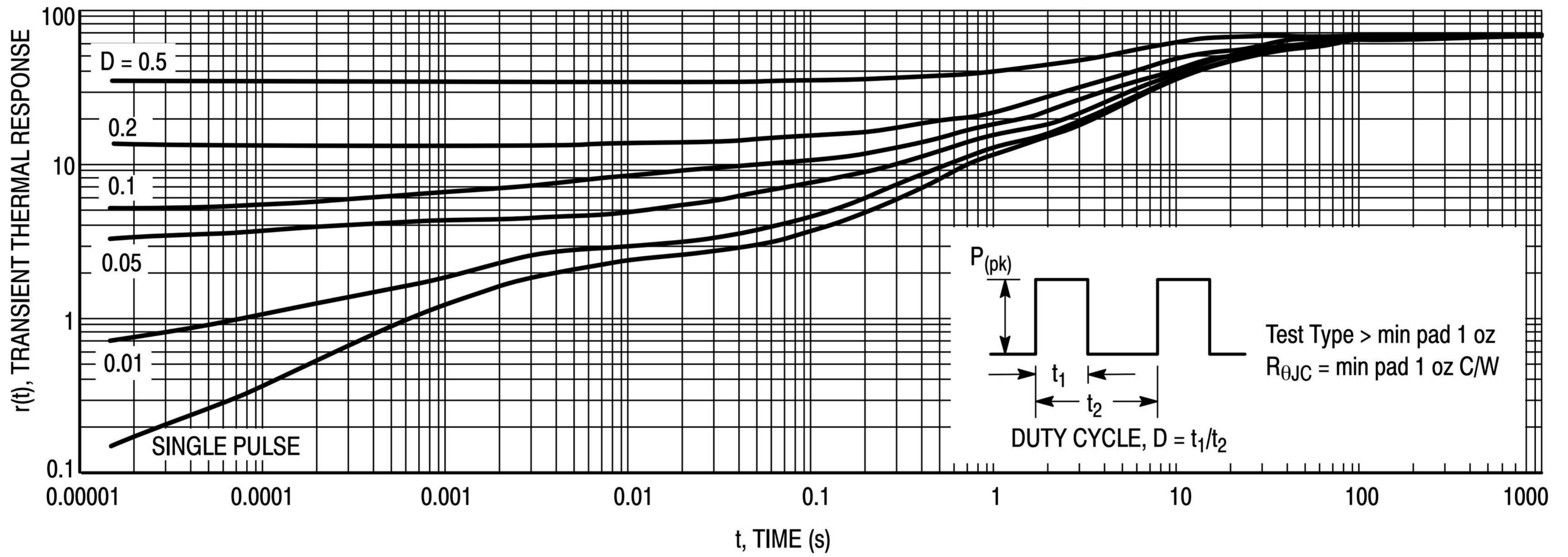

Figure 8. Thermal Response, Junction-to-Ambient, SMC Package

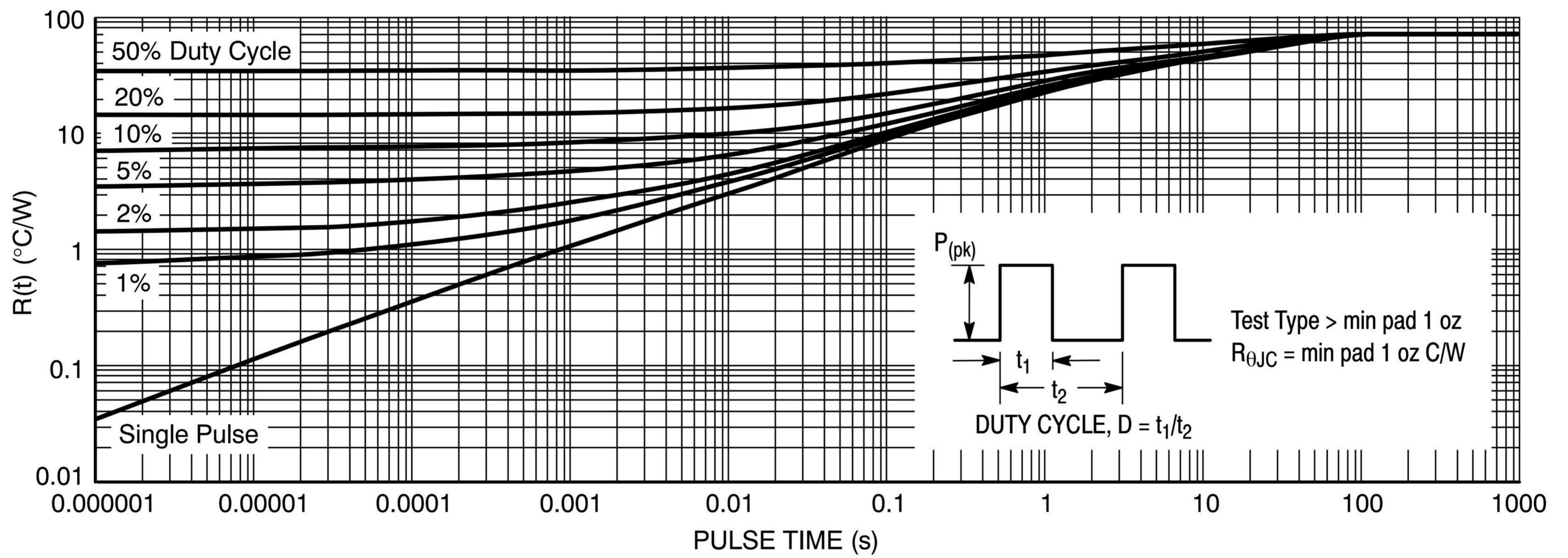

Figure 9. Typical Thermal Response, Junction-to-Ambient, SMB Package

OM SENI

Ordering Information

PACKAGE	PACKAGE CODE	UNIT WEIGHT(g)	REEL(pcs)	BOX(pcs)	CARTON(pcs)	DELIVERY MODE
SMC	R3	0.098	2500	5000	25000	13

Package Outline Dimensions (SMC/DO-214AB)

Symbol	Dimensions			
	Millimeters		Inches	
	Min.	Max.	Min.	Max.
A	2.85	3.27	0.112	0.129
B	6.60	7.11	0.261	0.281
C	5.59	6.22	0.221	0.246
D	1.99	2.61	0.078	0.103
E	0.76	1.52	0.030	0.060
F	-	0.20	-	0.008
G	7.75	8.13	0.306	0.321
H	0.15	0.31	0.006	0.012

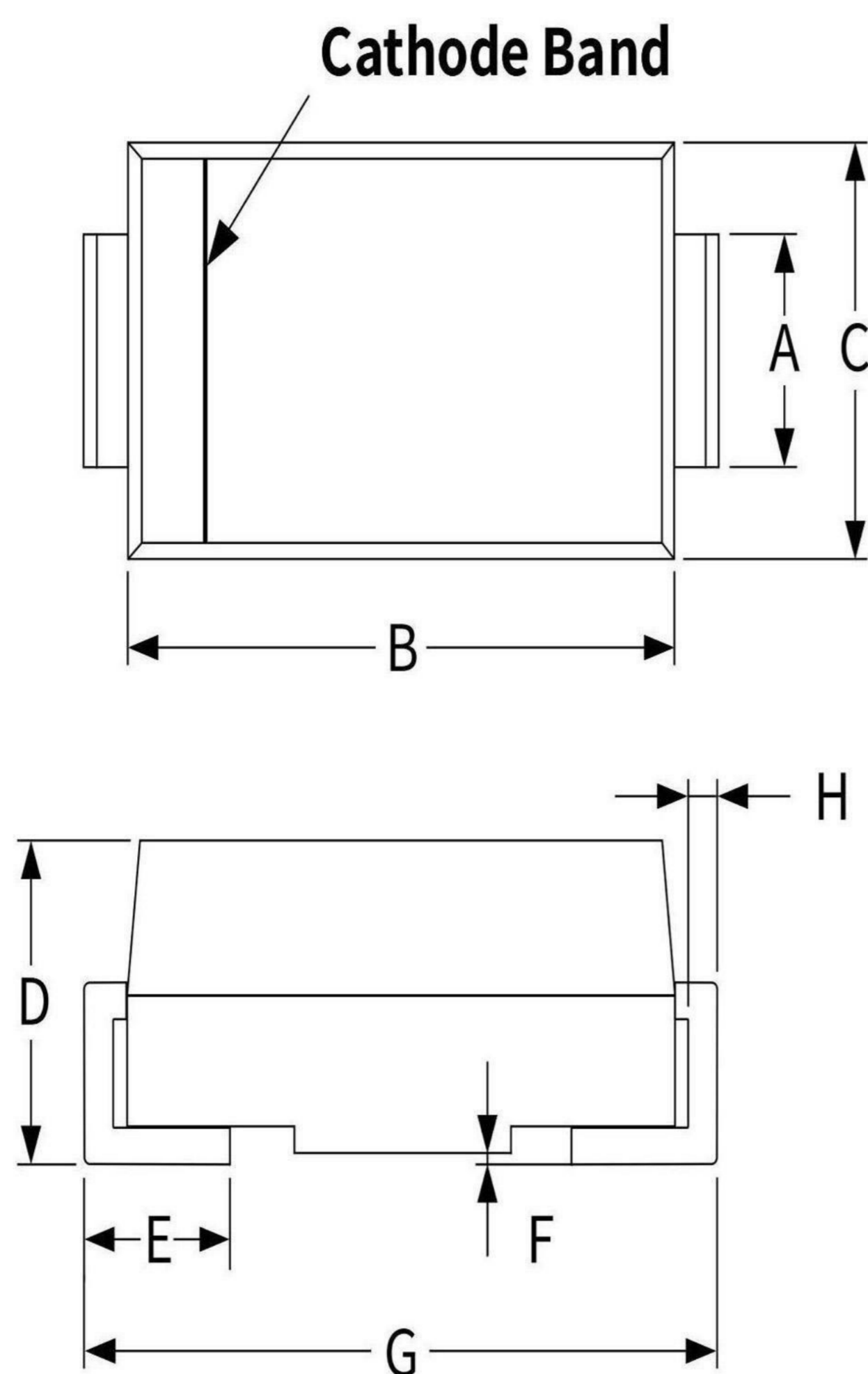

Suggested Pad Layout

Symbol	Dimensions			
	Millimeters		Inches	
	Min.	Max.	Min.	Max.
M	3.82	-	0.151	-
J	3.03	-	0.120	-
K	-	3.84	-	0.152

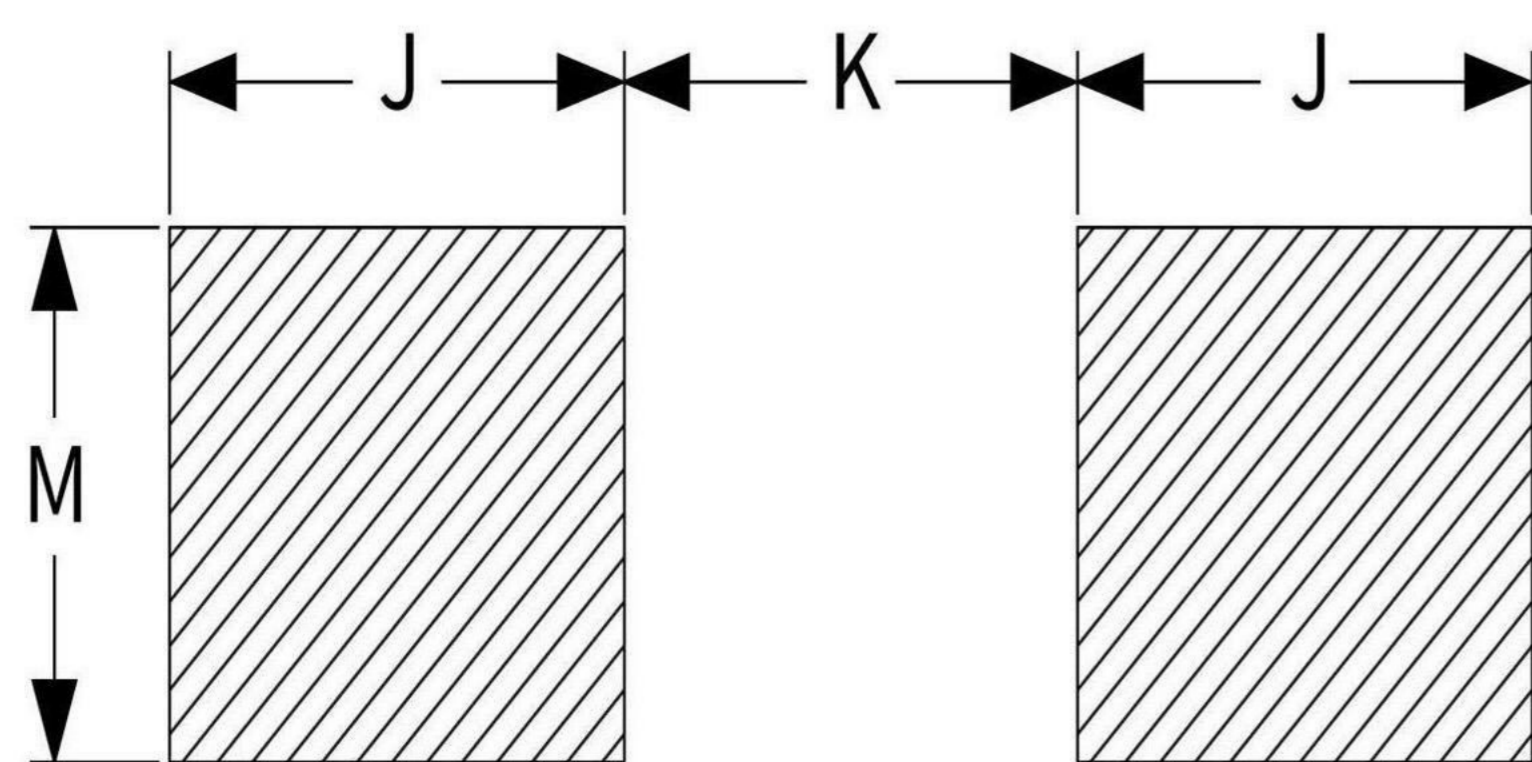

OM SENI

Ordering Information

PACKAGE	PACKAGE CODE	UNIT WEIGHT(g)	REEL(pcs)	BOX(pcs)	CARTON(pcs)	DELIVERY MODE
SMB	R3	0.098	2500	5000	25000	13

Package Outline Dimensions (SMB/DO-214AA)

Symbol	Dimensions			
	Millimeters		Inches	
	Min.	Max.	Min.	Max.
A	1.85	2.21	0.073	0.087
B	4.25	4.85	0.167	0.191
C	3.30	3.94	0.130	0.155
D	2.15	2.65	0.085	0.104
E	0.75	1.52	0.030	0.060
F	-	0.203	-	0.008
G	5.08	5.59	0.200	0.220
H	0.15	0.31	0.006	0.012

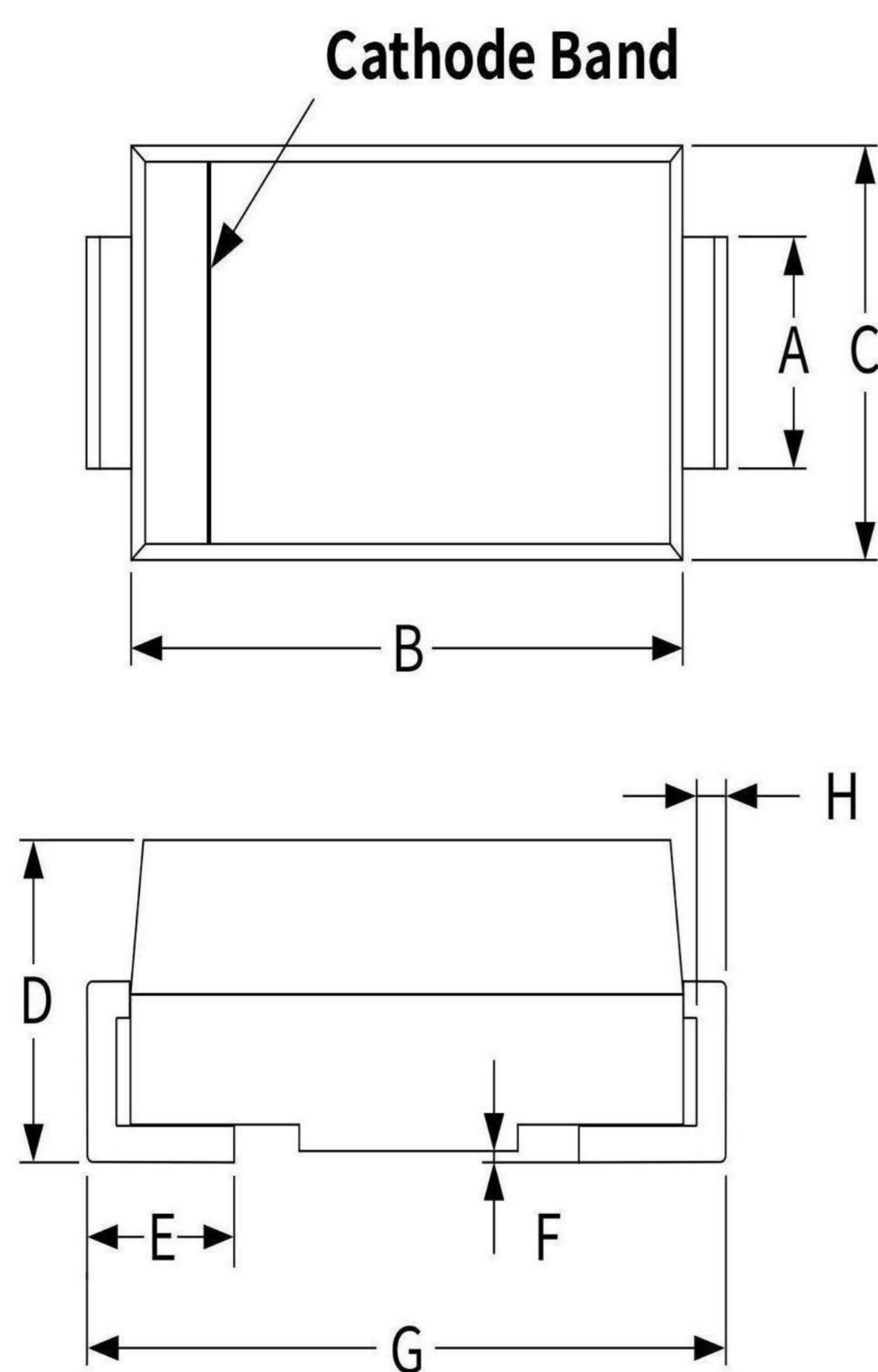

Suggested Pad Layout

Symbol	Dimensions			
	Millimeters		Inches	
	Min.	Max.	Min.	Max.
M	2.26	-	0.089	-
J	2.10	-	0.085	-
K	-	2.74	-	0.107

