

# OM SENI

## RB520S30T1G Schottky Barrier Diode

These Schottky barrier diodes are designed for high-speed switching applications, circuit protection, and voltage clamping. Extremely low forward voltage reduces conduction loss. Miniature surface mount package is excellent for hand-held and portable applications where space is limited.

### Features

- Extremely Fast Switching Speed
- Extremely Low Forward Voltage 0.6 V (max) @  $I_F = 200$  mA
- Low Reverse Current
- ESD Rating: Class 3B per Human Body Model  
Class C per Machine Model
- These Devices are Pb-Free, Halogen Free/BFR Free and are RoHS Compliant

### MAXIMUM RATINGS

Rating	Symbol	Value	Unit
Reverse Voltage	$V_R$	30	Vdc
Forward Current DC	$I_F$	200	mA

Stresses exceeding those listed in the Maximum Ratings table may damage the device. If any of these limits are exceeded, device functionality should not be assumed, damage may occur and reliability may be affected.

### THERMAL CHARACTERISTICS

Characteristic	Symbol	Max	Unit
Total Device Dissipation FR-5 Board, (Note 1) $T_A = 25^\circ\text{C}$ Derate above $25^\circ\text{C}$	$P_D$	200	mW
		1.57	mW/ $^\circ\text{C}$
Thermal Resistance, Junction-to-Ambient	$R_{\theta JA}$	635	$^\circ\text{C/W}$
Junction and Storage Temperature Range	$T_J, T_{stg}$	-55 to +150	$^\circ\text{C}$
Non-Repetitive Peak Forward Current, $t_p < 10$ msec	$I_{FSM}$	600	mA
Repetitive Peak Forward Current Pulse Wave = 1 sec, Duty Cycle = 66%	$I_{FRM}$	300	mA
Thermal Resistance, Junction-to-Ambient	$R_{\theta JA}$	635	$^\circ\text{C/W}$

1. FR-5 Minimum Pad.

### ELECTRICAL CHARACTERISTICS ( $T_A = 25^\circ\text{C}$ unless otherwise noted)

Characteristic	Symbol	Min	Typ	Max	Unit
Reverse Leakage ( $V_R = 10$ V)	$I_R$	-	-	1.0	$\mu\text{A}$
Forward Voltage ( $I_F = 200$ mA)	$V_F$	-	-	0.60	Vdc

### 30 VOLT SCHOTTKY BARRIER DIODE

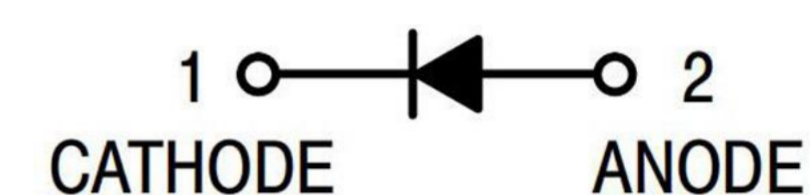

### MARKING DIAGRAM

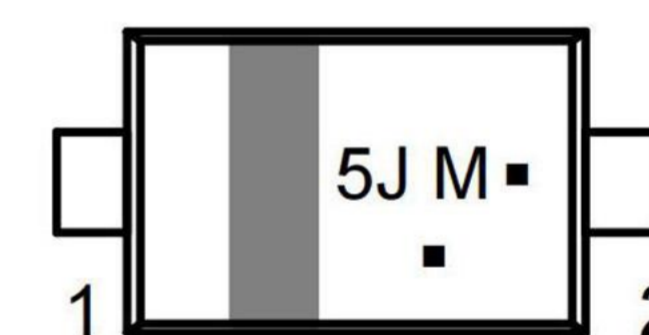

5J = Device Code  
M = Date Code\*  
■ = Pb-Free Package

(Note: Microdot may be in either location)

\*Date Code orientation position may vary depending upon manufacturing location.

# OM SENI

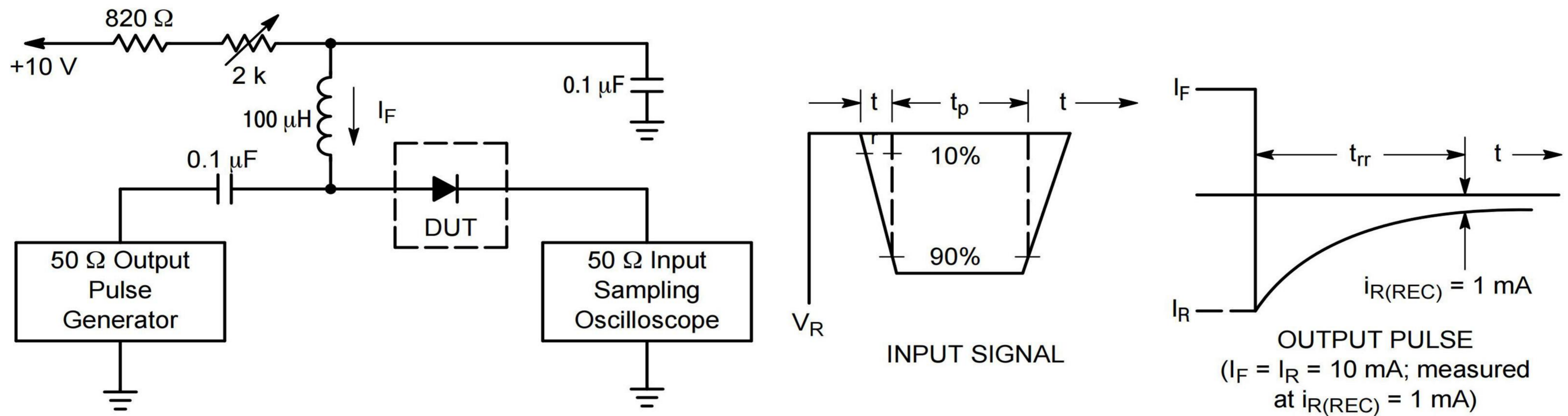

- Notes: 1. A 2.0 kΩ variable resistor adjusted for a Forward Current ( $I_F$ ) of 10 mA.  
 2. Input pulse is adjusted so  $I_{R(peak)}$  is equal to 10 mA.  
 3.  $t_p \gg t_{rr}$

Figure 1. Recovery Time Equivalent Test Circuit

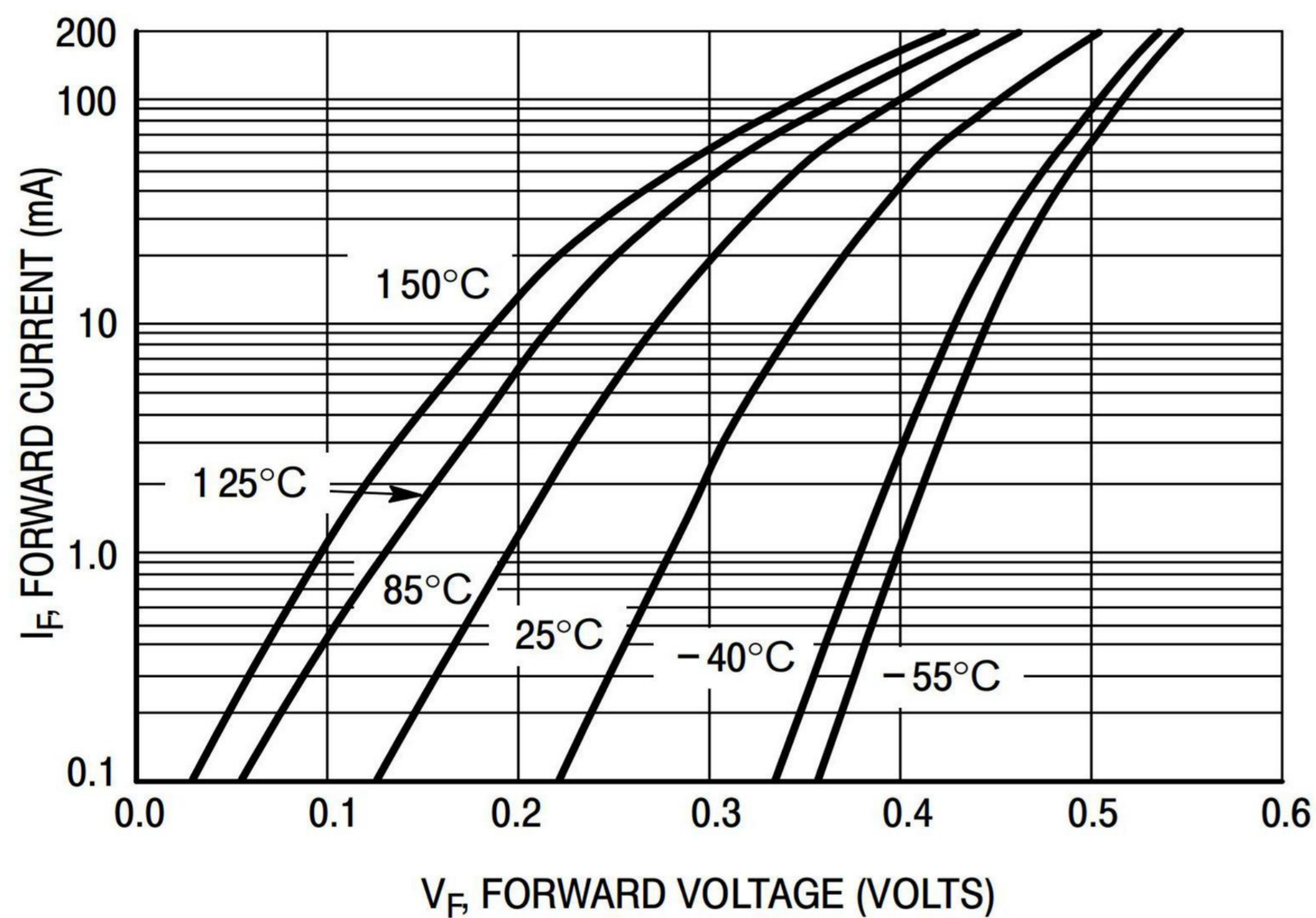

Figure 2. Forward Voltage

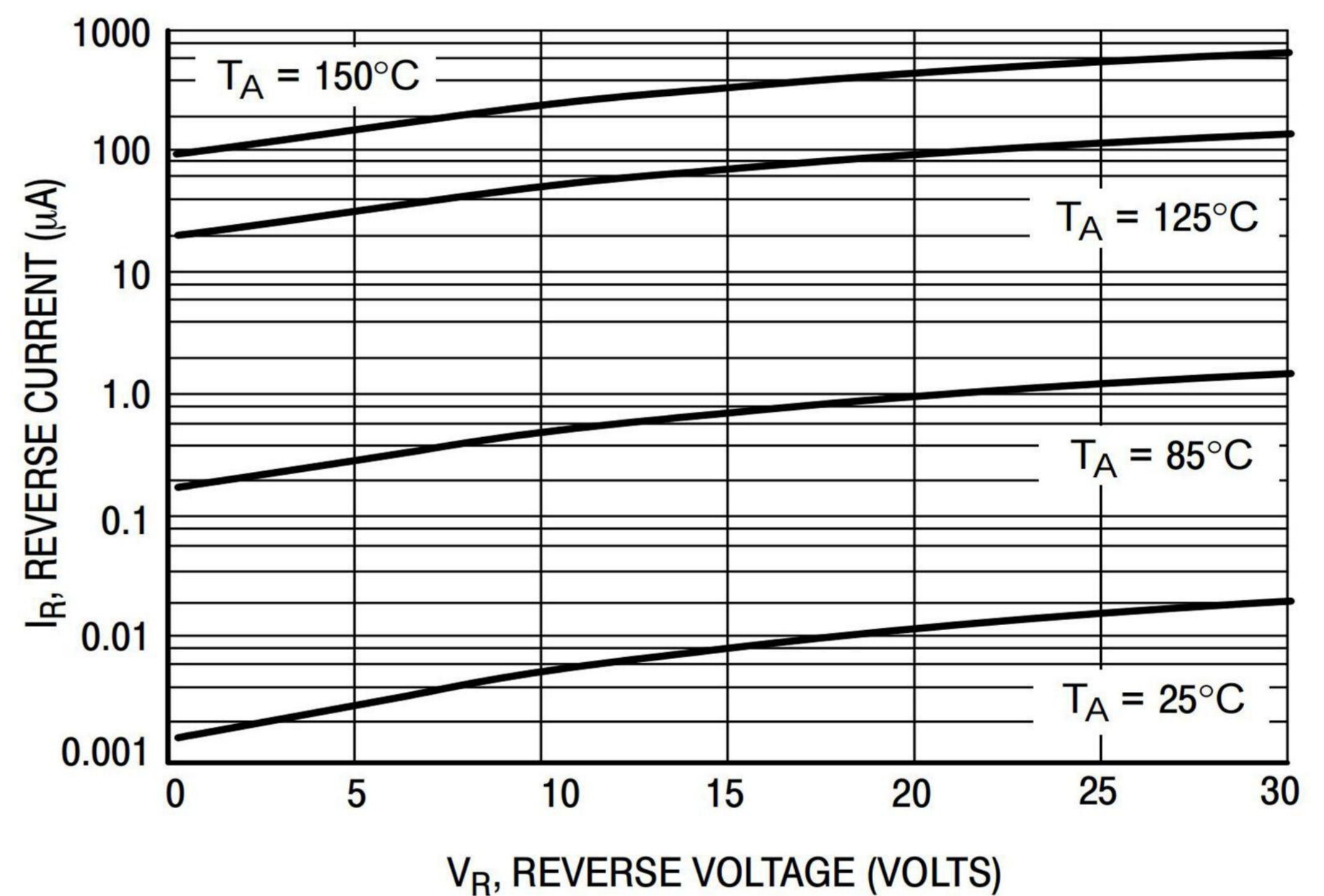

Figure 3. Leakage Current

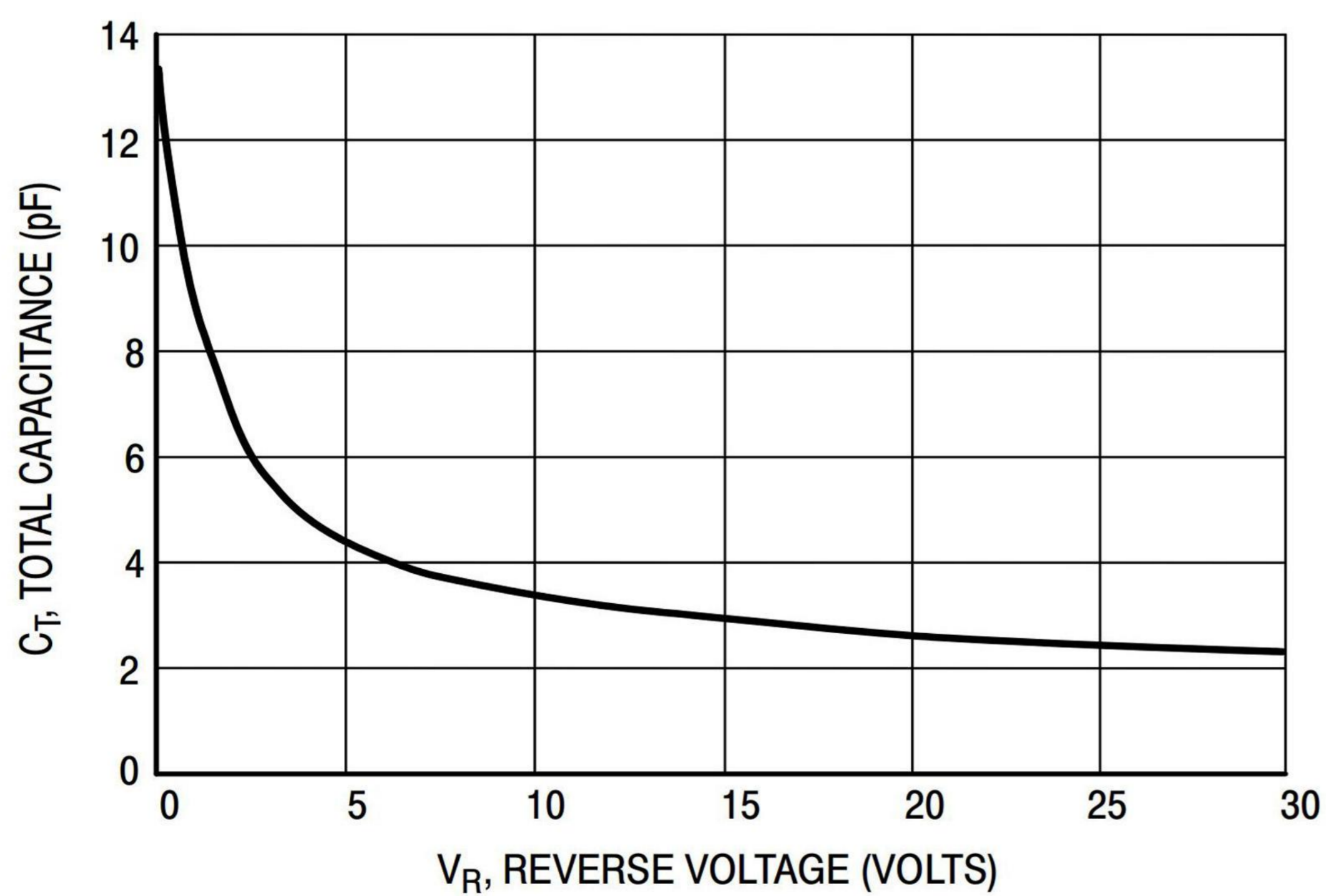

Figure 4. Total Capacitance

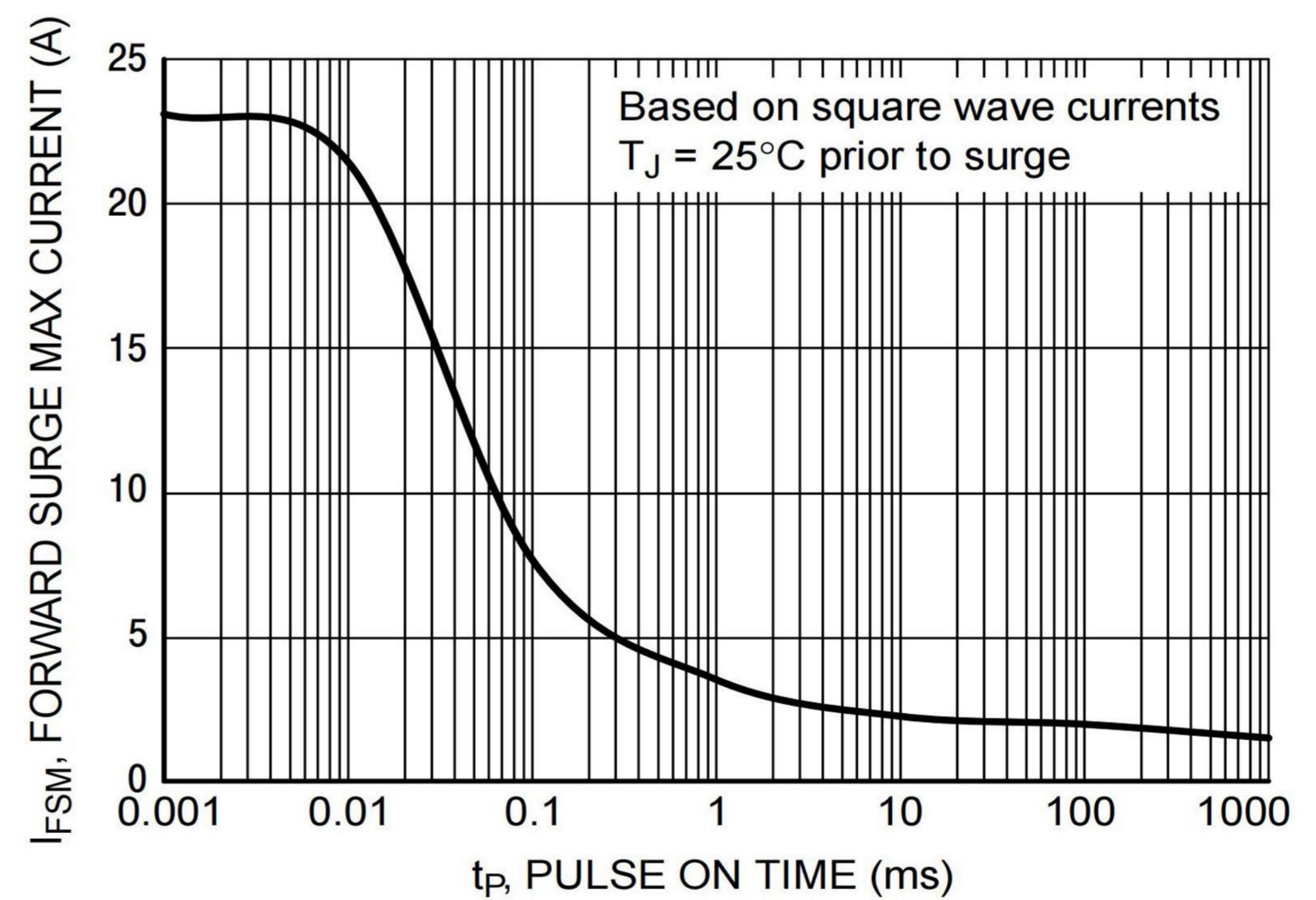

Figure 5. Forward Surge Current

# OM SENI

## Ordering Information

PACKAGE	PACKAGE CODE	UNIT WEIGHT(g)	REEL(pcs)	BOX(pcs)	CARTON(pcs)	DELIVERY MODE
SOD-523	R1	0.002	3000	45000	180000	7"

## Package Outline Dimensions (SOD-523)

Symbol	Dimensions			
	Millimeters		Inches	
	Min	Max	Min	Max
A	1.10	1.30	0.043	0.051
B	0.25	0.35	0.010	0.014
C	1.50	1.70	0.059	0.067
D	0.50	0.70	0.020	0.027
E	0.70	0.90	0.027	0.035
F	0.05	0.20	0.002	0.008

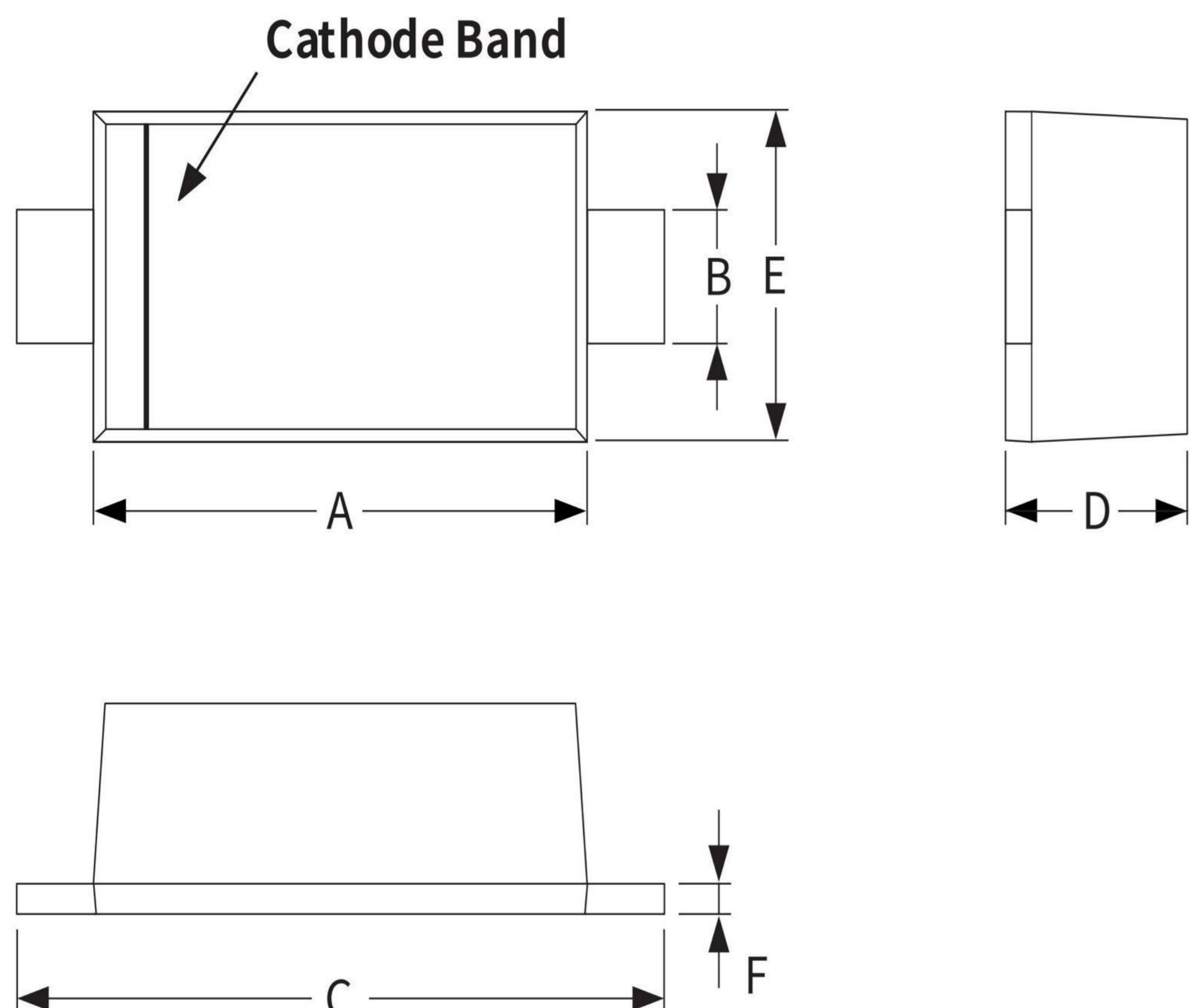

## Suggested Pad Layout

Symbol	Dimensions			
	Millimeters		Inches	
	Min.	Max.	Min.	Max.
X	0.55	0.65	0.022	0.026
Y	0.65	0.75	0.026	0.029
Z	1.37	1.47	0.054	0.058

